

ACS800

efesotomasyon.com

Hardware Manual

ACS800-02 Drives (45 to 560 kW)

ACS800-U2 Drives (60 to 600 HP)

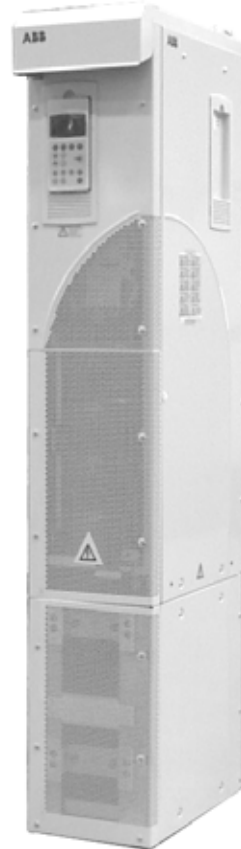

ABB

ACS800 Single Drive Manuals

HARDWARE MANUALS (appropriate manual is included in the delivery)

ACS800-01/U1 Hardware Manual 0.55 to 160 kW (0.75 to 200 HP)
3AFE64382101 (English)

ACS800-01/U1/04 Marine Supplement 0.55 to 160 kW (0.75 to 200 HP)
3AFE64291275 (English)

ACS800-11/U11 Hardware Manual 5.5 to 110 kW (7.5 to 125 HP)
3AFE68367883 (English)

ACS800-31/U31 Hardware Manual 5.5 to 110 kW (7.5 to 125 HP)
3AFE68599954 (English)

ACS800-02/U2 Hardware Manual 90 to 500 kW (125 to 600 HP)
3AFE64567373 (English)

ACS800-04/U4 Hardware Manual 0.55 to 160 kW (0.75 to 200 HP)
3AFE68372984 (English)

ACS800-04/04M/U4 Hardware Manual 45 to 560 kW (60 to 600 HP)
3AFE64671006 (English)

ACS800-04/04M/U4 Cabinet Installation 45 to 560 kW (60 to 600 HP)
3AFE68360323 (English)

ACS800-07/U7 Hardware Manual 45 to 560 kW (50 to 600 HP)
3AFE64702165 (English)

ACS800-07/U7 Dimensional Drawings 45 to 560 kW (50 to 600 HP)
3AFE64775421

ACS800-07 Hardware Manual 500 to 2800 kW
3AFE64731165 (English)

ACS800-17 Hardware Manual 55 to 2500 kW (75 to 2800 HP)
3AFE68397260 (English)

ACS800-37 Hardware Manual 55 to 2700 kW (75 to 3000 HP)
3AFE68557925 (English)

- Safety instructions
- Electrical installation planning
- Mechanical and electrical installation
- Motor control and I/O board (RMIO)
- Maintenance
- Technical data
- Dimensional drawings
- Resistor braking

FIRMWARE MANUALS, SUPPLEMENTS AND GUIDES

(appropriate documents are included in the delivery)

Standard Control Program Firmware Manual
3AFE64527592 (English)

System Control Program Firmware Manual
3AFE64670646 (English)

Control Program Template Firmware Manual
3AFE64616340 (English)

Master/Follower 3AFE64590430 (English)

Pump Control Program Firmware Manual
3AFE68478952 (English)

Extruder Control Program Supplement 3AFE64648543 (English)

Centrifuge Control Program Supplement 3AFE64667246 (English)

Traverse Control Program Supplement 3AFE64618334 (English)

Crane Control Program Firmware Manual 3BSE11179 (English)

Adaptive Programming Application Guide
3AFE64527274 (English)

OPTION MANUALS (delivered with optional equipment)

Fieldbus Adapters, I/O Extension Modules etc.

ACS800-02 Drives
45 to 560 kW
ACS800-U2 Drives
60 to 600 HP

efesotomasyon.com

Hardware Manual

3AFE64567373 Rev F EN
EFFECTIVE: 15.8.2007

Safety instructions

What this chapter contains

This chapter contains the safety instructions which you must follow when installing, operating and servicing the drive. If ignored, physical injury or death may follow, or damage may occur to the drive, motor or driven equipment. Read the safety instructions before you work on the unit.

To which products this chapter applies

This chapter applies to the ACS800-01/U1, ACS800-11/U11, ACS800-31/U31, ACS800-02/U2 and ACS800-04/04M/U4 of frame sizes R7 and R8.

Use of warnings and notes

There are two types of safety instructions throughout this manual: warnings and notes. Warnings caution you about conditions which can result in serious injury or death and/or damage to the equipment. They also tell you how to avoid the danger. Notes draw attention to a particular condition or fact, or give information on a subject. The warning symbols are used as follows:



Dangerous voltage warning warns of high voltage which can cause physical injury and/or damage to the equipment.



General warning warns about conditions, other than those caused by electricity, which can result in physical injury and/or damage to the equipment.



Electrostatic discharge warning warns of electrostatic discharge which can damage the equipment.



Hot surface warning warns of hot surfaces which can cause physical injury.

Installation and maintenance work

These warnings are intended for all who work on the drive, motor cable or motor.



WARNING! Ignoring the following instructions can cause physical injury or death, or damage to the equipment:

- **Only qualified electricians are allowed to install and maintain the drive.**
- Never work on the drive, motor cable or motor when main power is applied. After disconnecting the input power, always wait for 5 min to let the intermediate circuit capacitors discharge before you start working on the drive, motor or motor cable.

Always ensure by measuring with a multimeter (impedance at least 1 Mohm) that:

1. voltage between drive input phases U1, V1 and W1 and the frame is close to 0 V.
 2. voltage between terminals UDC+ and UDC- and the frame is close to 0 V.
- Do not work on the control cables when power is applied to the drive or to the external control circuits. Externally supplied control circuits may cause dangerous voltages inside the drive even when the main power on the drive is switched off.
 - Do not make any insulation or voltage withstand tests on the drive or drive modules.
 - When reconnecting the motor cable, always check that the phase order is correct.

Note:

- The motor cable terminals on the drive are at a dangerously high voltage when the input power is on, regardless of whether the motor is running or not.
- The brake control terminals (UDC+, UDC-, R+ and R- terminals) carry a dangerous DC voltage (over 500 V).
- Depending on the external wiring, dangerous voltages (115 V, 220 V or 230 V) may be present on the terminals of relay outputs RO1 to RO3 or on the optional AGPS board (Prevention of Unexpected Start, ACS800-01/U1, ACS800-04/04M, ACS800-11/U11, ACS800-31/U31).
- ACS800-02 with enclosure extension: The main switch on the cabinet door does not remove the voltage from the input busbars of the drive. Before working on the drive, isolate the whole drive from the supply.
- ACS800-01/U1, ACS800-04/04M, ACS800-11/U11, ACS800-31/U31: The Prevention of Unexpected Start function does not remove the voltage from the main and auxiliary circuits.

- At installation sites above 2000 m (6562 ft), the terminals of the RMIO board and optional modules attached to the board do not fulfil the Protective Extra Low Voltage (PELV) requirements stated in EN 50178.
-

Grounding

These instructions are intended for all who are responsible for the grounding of the drive.



WARNING! Ignoring the following instructions can cause physical injury, death, increased electromagnetic interference and equipment malfunction:

- Ground the drive, motor and adjoining equipment to ensure personnel safety in all circumstances, and to reduce electromagnetic emission and interference.
- Make sure that grounding conductors are adequately sized as required by safety regulations.
- In a multiple-drive installation, connect each drive separately to protective earth (PE).
- ACS800-01, ACS800-11, ACS800-31: In European CE compliant installations and in other installations where EMC emissions must be minimized, make a 360° high frequency grounding of cable entries in order to suppress electromagnetic disturbances. In addition, connect the cable shields to protective earth (PE) in order to meet safety regulations.

ACS800-04 (45 to 560 kW) and ACS800-02 in first environment: make a 360° high frequency grounding of motor cable entries at the cabinet lead-through.

- Do not install a drive with EMC filter option +E202 or +E200 (available for ACS800-01 and ACS800-11, ACS800-31 only) on an ungrounded power system or a high-resistance-grounded (over 30 ohms) power system.

Note:

- Power cable shields are suitable for equipment grounding conductors only when adequately sized to meet safety regulations.
 - As the normal leakage current of the drive is higher than 3.5 mA AC or 10 mA DC (stated by EN 50178, 5.2.11.1), a fixed protective earth connection is required.
-

Mechanical installation and maintenance

These instructions are intended for all who install and service the drive.



WARNING! Ignoring the following instructions can cause physical injury or death, or damage to the equipment:

- Handle the unit carefully.
- ACS800-01, ACS800-11, ACS800-31: The drive is heavy. Do not lift it alone. Do not lift the unit by the front cover. Place the unit only on its back.

ACS800-02, ACS800-04: The drive is heavy. Lift the drive by the lifting lugs only. Do not tilt the unit. The unit will overturn from a tilt of about 6 degrees. Use extreme caution when manoeuvring a drive that runs on wheels. **An overturning unit can cause physical injury.**

Do not tilt!

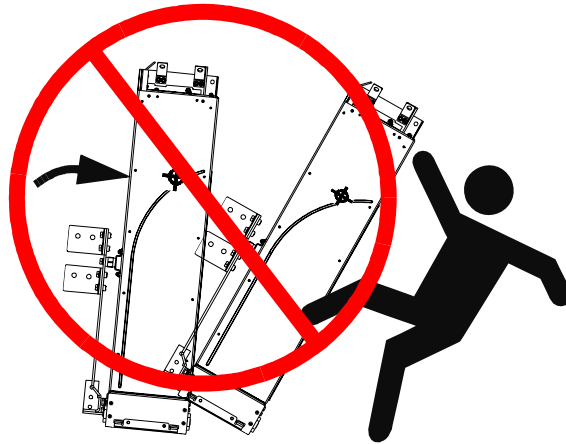

- Beware of hot surfaces. Some parts, such as heatsinks of power semiconductors, remain hot for a while after disconnection of the electrical supply.
- Make sure that dust from borings and grindings does not enter the drive when installing. Electrically conductive dust inside the unit may cause damage or malfunctioning.
- Ensure sufficient cooling.
- Do not fasten the drive by riveting or welding.

Printed circuit boards



WARNING! Ignoring the following instructions can cause damage to the printed circuit boards:

- The printed circuit boards contain components sensitive to electrostatic discharge. Wear a grounding wrist band when handling the boards. Do not touch the boards unnecessarily.
-

Fibre optic cables



WARNING! Ignoring the following instructions can cause equipment malfunction and damage to the fibre optic cables:



- Handle the fibre optic cables with care. When unplugging optic cables, always grab the connector, not the cable itself. Do not touch the ends of the fibres with bare hands as the fibre is extremely sensitive to dirt. The minimum allowed bend radius is 35 mm (1.4 in.).
-

Operation

These warnings are intended for all who plan the operation of the drive or operate the drive.



WARNING! Ignoring the following instructions can cause physical injury or death, or damage to the equipment:

- Before adjusting the drive and putting it into service, make sure that the motor and all driven equipment are suitable for operation throughout the speed range provided by the drive. The drive can be adjusted to operate the motor at speeds above and below the speed provided by connecting the motor directly to the power line.
- Do not activate automatic fault reset functions of the Standard Control Program if dangerous situations can occur. When activated, these functions will reset the drive and resume operation after a fault.
- Do not control the motor with the disconnecting device (disconnecting means); instead, use the control panel keys  and , or commands via the I/O board of the drive. The maximum allowed number of charging cycles of the DC capacitors (i.e. power-ups by applying power) is five in ten minutes.

Note:

- If an external source for start command is selected and it is ON, the drive (with Standard Control Program) will start immediately after fault reset unless the drive is configured for 3-wire (a pulse) start/stop.
 - When the control location is not set to Local (L not shown in the status row of the display), the stop key on the control panel will not stop the drive. To stop the drive using the control panel, press the LOC/REM key and then the stop key .
-

Permanent magnet motor

These are additional warnings concerning permanent magnet motor drives. Ignoring the instructions can cause physical injury or death, or damage to the equipment.

Installation and maintenance work



WARNING! Do not work on the drive when the permanent magnet motor is rotating. Also, when the supply power is switched off and the inverter is stopped, a rotating permanent magnet motor feeds power to the intermediate circuit of the drive and the supply connections become live.

Before installation and maintenance work on the drive:

- Stop the motor.
- Ensure that the motor cannot rotate during work. Prevent the start-up of any drives in the same mechanical group by opening the “prevention of unexpected start” switch and padlocking it. Make sure that no other system, like hydraulic crawling drives, are able to rotate the motor directly or through any mechanical connection like felt, nip, rope, etc.
- Ensure that there is no voltage on the drive power terminals:
 - Alternative 1)* Disconnect the motor from the drive with a safety switch or by other means. Measure that there is no voltage present on the drive input or output terminals (U1, V1, W1, U2, V2, W2, UDC+, UDC-).
 - Alternative 2)* Measure that there is no voltage present on the drive input or output terminals (U1, V1, W1, U2, V2, W2, UDC+, UDC-). Ground the drive output terminals temporarily by connecting them together as well as to the PE.
 - Alternative 3)* If possible, both of the above.

Start-up and operation



WARNING! Do not run the motor over the rated speed. Motor overspeed leads to overvoltage which may damage or explode the capacitors in the intermediate circuit of the drive.

Controlling a permanent magnet motor is only allowed using the control program for Permanent Magnet Synchronous Machine Drive, or other control programs in scalar control mode.

Table of contents

ACS800 Single Drive Manuals	2
-----------------------------------	---

Safety instructions

What this chapter contains	5
To which products this chapter applies	5
Use of warnings and notes	5
Installation and maintenance work	6
Grounding	7
Mechanical installation and maintenance	8
Printed circuit boards	9
Fibre optic cables	9
Operation	10
Permanent magnet motor	11
Installation and maintenance work	11
Start-up and operation	11

Table of contents

About this manual

What this chapter contains	19
Intended audience	19
Common chapters for several products	19
Categorization according to the frame size	19
Contents	19
Installation and commissioning flowchart	20
Product and service inquiries	21
Product training	21
Providing feedback on ABB Drives manuals	21

The ACS800-02/U2

What this chapter contains	23
The ACS800-02/U2	23
Enclosure extension	24
Type code	24
Main circuit and control	26
Diagram	26
Operation	27
Printed circuit boards	27
Motor control	27

Planning the electrical installation

What this chapter contains	29
To which products this chapter applies	29
Motor selection and compatibility	29
Protecting the motor insulation and bearings	31
Requirements table	32
Permanent magnet synchronous motor	35
Supply connection	36
Disconnecting device (disconnecting means)	36
ACS800-01, ACS800-U1, ACS800-11, ACS800-U11, ACS800-31, ACS800-U31, ACS800-02 and ACS800-U2 without enclosure extension, ACS800-04, ACS800-U4	36
ACS800-02 and ACS800-U2 with enclosure extension, ACS800-07 and ACS800-U7	36
EU	36
US	36
Fuses	36
Main contactor	36
Thermal overload and short-circuit protection	37
Thermal overload protection of the drive and the input and motor cables	37
Thermal overload protection of the motor	37
Protection against short-circuit in the motor cable	37
Protection against short-circuit inside the drive or in the supply cable	38
Ground fault protection	39
Emergency stop devices	39
ACS800-02/U2 with enclosure extension and ACS800-07/U7	39
Restarting after an emergency stop	39
Power-loss ride-through function	40
ACS800-07/U7 units without line contactor	40
ACS800-07/U7 units with line contactor (+F250)	40
Prevention of Unexpected Start	41
Selecting the power cables	42
General rules	42
Alternative power cable types	43
Motor cable shield	43
Additional US requirements	44
Conduit	44
Armored cable / shielded power cable	44
Power factor compensation capacitors	44
Equipment connected to the motor cable	45
Installation of safety switches, contactors, connection boxes, etc.	45
Bypass connection	45
Before opening a contactor (DTC control mode selected)	45
Protecting the relay output contacts and attenuating disturbances in case of inductive loads	46
Selecting the control cables	47
Relay cable	47
Control panel cable	47
Connection of a motor temperature sensor to the drive I/O	48
Installation sites above 2000 metres (6562 feet)	48
Routing the cables	48
Control cable ducts	49

Installation

What this chapter contains	51
Moving the unit	51
Before installation	53
Delivery check	53
Requirements for the installation site	54
Wall	54
Floor	54
Free space around the unit	54
Cooling air flow	54
IT (ungrounded) systems	55
Required tools	55
Checking the insulation of the installation	55
Drive	55
Input cable	55
Motor and motor cable	55
Power cable connection diagram	56
Installation procedure	57
Choose the mounting orientation (a, b, c or d)	57
Mounting orientations a and b	57
Mounting orientation c (lifting from above)	65
Mounting orientation d (optional enclosure extension included)	66
Fastening the unit	66
Connecting the power cables	67
Enclosure extension layout	75
Main wiring diagram	80
Routing the control/signal cables inside the cubicle	81
Units without an enclosure extension	81
Units with enclosure extension	82
Connecting the control cables	83
Connecting the shield wires at RMIO board	83
Securing the control cables mechanically	83
Settings of the cooling fan transformer	84
Setting of the auxiliary voltage transformer of the line contactor option	84
Installation of optional modules and PC	84
Cabling of I/O and fieldbus modules	84
Pulse encoder module cabling	85
Fibre optic link	85
Installation of user's own relays	85
Installation of brake resistors	85
Parameter settings	85
Fill-in user connections diagram	86
Wiring diagram template	87

Motor control and I/O board (RMIO)

What this chapter contains	89
To which products this chapter applies	89
Note for the ACS800-02 with enclosure extension and the ACS800-07	89

Note on terminal labelling	.89
Note on external power supply	.90
Parameter settings	.90
External control connections (non-US)	.91
External control connections (US)	.92
RMIO board specifications	.93
Analogue inputs	.93
Constant voltage output	.93
Auxiliary power output	.93
Analogue outputs	.93
Digital inputs	.93
Relay outputs	.94
DDCS fibre optic link	.94
24 VDC power input	.94

Installation checklist

Checklist	.97
-----------	-----

Maintenance

What this chapter contains	.99
Safety	.99
Maintenance intervals	.99
Layout	100
Heatsink	101
Fan	101
Replacing the fan(s) of the enclosure extension	102
Replacing the fan (R7)	103
Replacing the fan (R8)	104
Capacitors	105
Reforming	105
Replacing the capacitor pack (R7)	105
Replacing the capacitor pack (R8)	106
Module replacement of units with the enclosure extension	107
LEDs	108

Technical data

What this chapter contains	109
IEC data	109
Ratings	109
Symbols	111
Sizing	111
Derating	111
Temperature derating	111
Altitude derating	111
Fuses	112
Calculation example	112
Fuse tables	113
Ultrarapid (aR) fuses	113
gG fuses	114
Quick guide for selecting between gG and aR fuses	116
Cable types	117
Cable entries	118
Dimensions, weights and noise	118
NEMA data	119
Ratings	119
Symbols	120
Sizing	120
Derating	120
Fuses	120
UL class T and L fuses	121
Cable types	122
Cable entries	123
Dimensions, weights and noise	123
Input power connection	124
Motor connection	124
Efficiency	124
Cooling	125
Degrees of protection	125
Ambient conditions	125
Materials	126
Applicable standards	126
US patents	126
CE marking	127
Definitions	127
Compliance with the EMC Directive	127
Compliance with the and EN 61800-3 (2004)	127
First environment (drive of category C2)	127
Second environment (drive of category C3)	128
Second environment (drive of category C4)	128
Machinery Directive	128

“C-tick” marking	129
Definitions	129
Compliance with IEC 61800-3	129
First environment (drive of category C2)	129
Second environment (drive of category C3)	130
Second environment (drive of category C4)	130
UL/CSA markings	131
UL	131
Equipment warranty and liability	131

Dimensional drawings

Frame size R7	134
Frame size R8	135
Frame size R7 with enclosure extension – bottom entry	136
Frame size R7 with enclosure extension – top entry	138
Frame size R8 with enclosure extension – bottom entry	140
Frame size R8 with enclosure extension – top entry	142

Resistor braking

What this chapter contains	145
To which products this chapter applies	145
Availability of brake choppers and resistors for the ACS800	145
How to select the correct drive/chopper/resistor combination	145
Optional brake chopper and resistor(s) for the ACS800-01/U1	146
Optional brake chopper and resistor(s) for the ACS800-02/U2, ACS800-04/04M/U4 and ACS800-07/U7	149
Resistor installation and wiring	151
ACS800-07/U7	152
Protection of frame sizes R2 to R5 (ACS800-01/U1)	152
Protection of frame size R6 (ACS800-01, ACS800-07) and frame sizes R7 and R8 (ACS800-02, ACS800-04, ACS800-07)	152
Brake circuit commissioning	153

Non-ABB du/dt filter selection

What this chapter contains	155
When a du/dt filter must be used	155
Filter and installation requirements	155

About this manual

What this chapter contains

This chapter describes the intended audience and contents of the manual. It contains a flowchart of steps in checking the delivery, installing and commissioning the drive. The flowchart refers to chapters/sections in the manual and other manuals.

Intended audience

This manual is intended for people who plan the installation, install, commission, use and service the drive. Read the manual before working on the drive. The reader is expected to know the fundamentals of electricity, wiring, electrical components and electrical schematic symbols.

This manual is written for readers worldwide. Both SI and imperial units are shown. Special US instructions for installations within the United States that must be installed per the National Electrical Code and local codes are marked with (US).

Common chapters for several products

Four chapters of this manual, *Safety instructions*, *Planning the electrical installation*, *Motor control and I/O board (RMIO)* and *Resistor braking*, apply to several ACS800 products which are listed at the beginning of the chapters.

Categorization according to the frame size

Some instructions, technical data and dimensional drawings which concern only certain frame sizes are marked with the symbol of the frame size R2, R3... or R8. The frame size is not marked on the drive designation label. To identify the frame size of your drive, see the rating tables in chapter *Technical data*.

Contents

The chapters of this manual are briefly described below.

Safety instructions give safety instructions for the installation, commissioning, operation and maintenance of the drive.

About this manual introduces this manual.

[The ACS800-02/U2](#) describes the drive.

[Planning the electrical installation](#) instructs on the motor and cable selection, the protections and the cable routing.

[Installation](#) instructs how to place, mount and wire the drive.

[Motor control and I/O board \(RMIO\)](#) shows external control connections to the motor control and I/O board and its specifications.

[Installation checklist](#) helps in checking the mechanical and electrical installation of the drive.

[Maintenance](#) contains preventive maintenance instructions.

[Technical data](#) contains the technical specifications of the drive, e.g. the ratings, sizes and technical requirements, provisions for fulfilling the requirements for CE and other markings and warranty policy.

[Dimensional drawings](#) contains the dimensional drawings of the drive.

[Resistor braking](#) describes how to select, protect and wire optional brake choppers and resistors. The chapter also contains technical data.

[Non-ABB du/dt filter selection](#) contains guidelines on selecting and installing a non-ABB du/dt filter with the drive.

Installation and commissioning flowchart

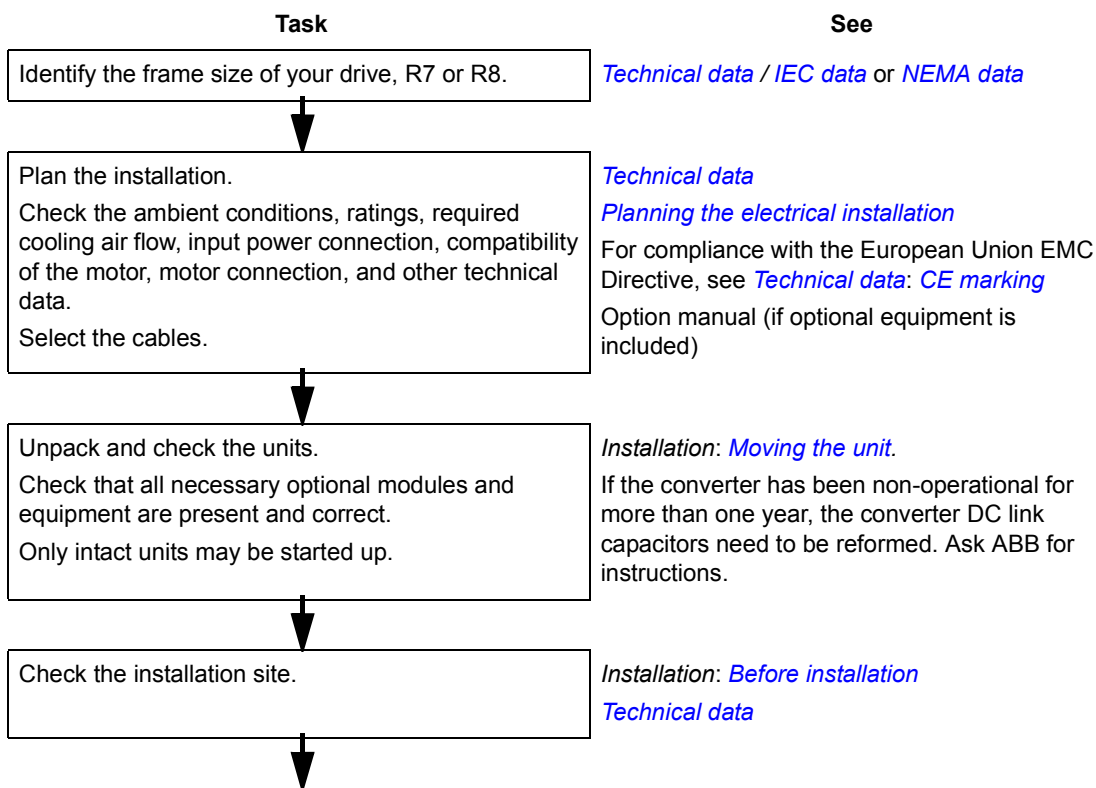

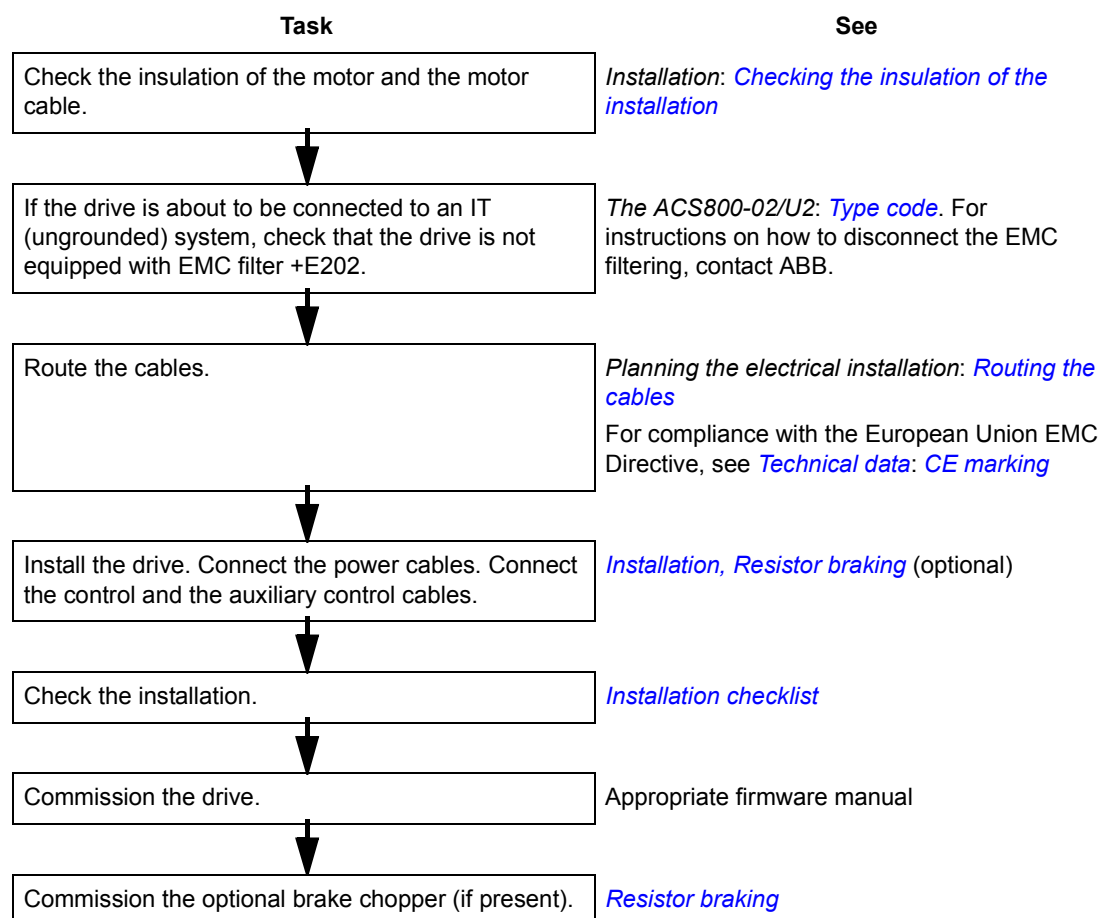

Product and service inquiries

Address any inquiries about the product to your local ABB representative, quoting the type code and serial number of the unit in question. A listing of ABB sales, support and service contacts can be found by navigating to www.abb.com/drives and selecting *Drives – Sales, Support and Service network* on the right pane.

Product training

For information on ABB product training, navigate to www.abb.com/drives and select *Drives – Training courses* on the right pane.

Providing feedback on ABB Drives manuals

Your comments on our manuals are welcome. Go to www.abb.com/drives, then select successively *Drives – Document Library – Manuals feedback form* on the right pane.

The ACS800-02/U2

What this chapter contains

This chapter describes the construction and operating principle of the drive in short.

The ACS800-02/U2

The ACS800-02 is a free-standing drive for controlling AC motors. In the basic unit, the cabling direction is from below. When an optional enclosure extension is connected next to the basic unit, the cables can also be led from above. The ACS800-U2 is a US version of the drive.

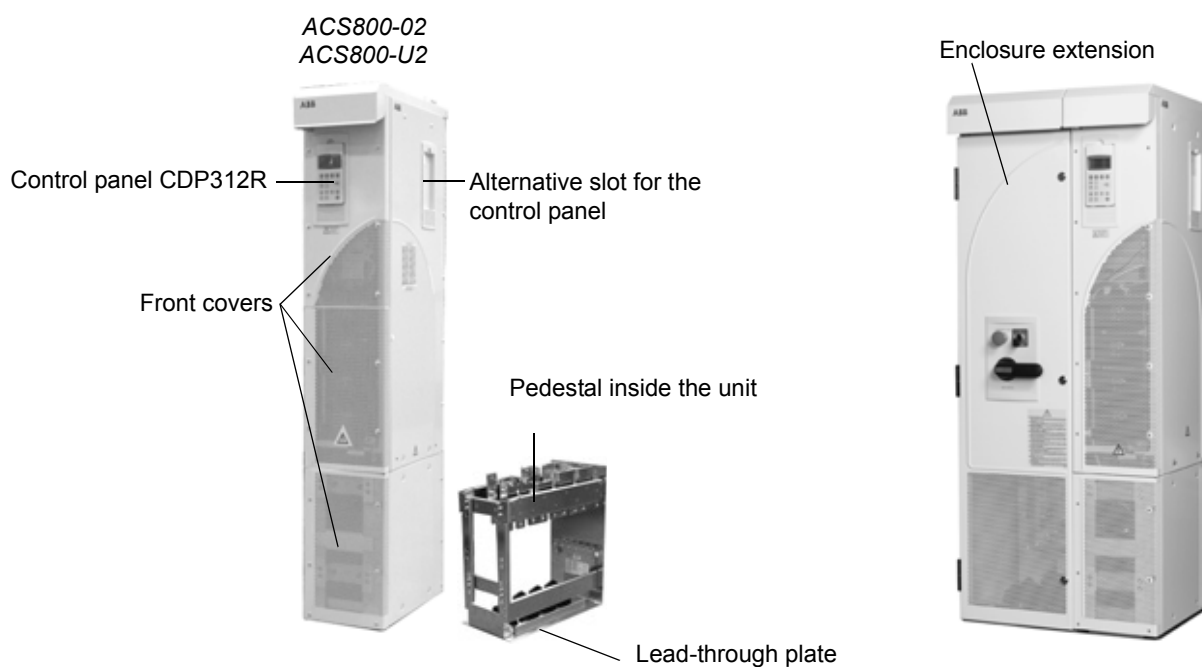

Enclosure extension

The extension can be used for accommodating customer equipment; it is also automatically added whenever required by factory-installed options such as

- switch fuse (always included with the enclosure extension)
- line contactor with Category 0 emergency stop devices (start/stop and emergency stop switches included)
- thermistor relay(s)
- Pt100 relays
- top cable entry/exit
- additional I/O terminal block.

Type code

The type code contains information on the specifications and configuration of the drive. The first digits from left express the basic configuration (e.g. ACS800-02-0170-5). The optional selections are given thereafter, separated by plus signs (e.g. +E202). The main selections are described below. Not all selections are available for all types. For more information, refer to *ACS800 Ordering Information* (EN code: 64556568, available on request).

Type code selections for the ACS800-02		
Selection	Alternatives	
Product series	ACS800 product series	
Type	02	free standing. When no options are selected: 6-pulse diode input bridge, IP 21, Control Panel CDP312R, no EMC filter, Standard Control Program, no enclosure extension, cabling from below, boards without coating, one set of manuals.
Size	Refer to <i>Technical data: IEC data</i> or <i>NEMA data</i>	
Voltage range (nominal rating in bold)	2	208/220/ 230 /240 VAC
	3	380/ 400 /415 VAC
	5	380/400/415/440/460/480/ 500 VAC
	7	525/575/600/ 690 VAC
+ options		
Construction	C111	enclosure extension (bottom entry/exit, switch fuse with aR fuses)
	C127	US enclosure extension (US door interlock disconnect switch fuse with T/L fuses, US gland/conduit plate, all components UL/cUL approved)
Resistor braking	D150	brake chopper
Filter	E202	EMC/RFI filter for first environment TN (grounded) system, restricted (the A limits)
	E210	EMC/RFI filter for second environment TN/IT (grounded/ungrounded) system
	E208	common mode filter
Line options (+C111 or +C127 required)	F250	line contactor
	Q951	emergency stop of category 0
	F251	gG line fuses
Cabinet options (+C111 or +C127 required)	G304	115 VAC auxiliary voltage transformer
Cabling	H351	top entry (+C111+H353 required)
	H353	top exit (+C111+H351 required)
	H358	US/UK gland/conduit plate

Type code selections for the ACS800-02		
Selection	Alternatives	
Control panel	0J400	no control panel, LEDs on the panel mounting platform included
I/O	L504	additional terminal block X2 (+C111 required)
	L505	thermistor relay (1 or 2 pcs, +C111 required)
	L506	Pt100 relay (3 pcs, +C111 required)
	L...	Refer to <i>ACS800 Ordering Information</i> (EN code: 64556568).
Fieldbus	K...	Refer to <i>ACS800 Ordering Information</i> (EN code: 64556568).
Control program	N...	
Language of manual	R...	
Specialities	P901	coated boards
	P904	extended warranty

Type code selections for the ACS800-U2		
Selection	Alternatives	
Product series	ACS800 product series	
Type	U2	free standing (USA). When no options are selected: 6-pulse diode bridge, UL type 1, Control Panel CDP312R, no EMC filter, US version of the Standard Control Program (three-wire start/stop as default setting), US enclosure extension (top entry, top exit), class T/L fuses, US gland/conduit plate, common mode filter in frame size R8, boards without coating, one set of manuals.
Size	Refer to <i>Technical data: NEMA data</i> .	
Voltage range (nominal rating in bold)	2	208/220/ 230 /240 VAC
	5	380/400/415/440/ 460 /480 VAC
	7	525/ 575 /600 VAC
+ options		
Construction	0C111	no enclosure extension, bottom entry/exit of cables
Resistor braking	D150	brake chopper
Filter	E202	EMC/RFI filter for first environment TN (grounded) system, restricted (the A limits)
	E210	EMC/RFI filter for second environment TN/IT (grounded/ungrounded) system
	E208	common mode filter for frame size R7
Line options (enclosure extension required)	F250	line contactor
	Q951	emergency stop of category 0
Cabinet options (enclosure extension required)	G320	230 VAC auxiliary voltage transformer
Cabling	H350	bottom entry (+H352 required)
	H352	bottom exit (+H350 required)
	H357	European lead-through plate
Control panel	0J400	no control panel, LEDs on the panel mounting platform included
I/O	L504	additional terminal block X2
	L505	thermistor relay (1 or 2 pcs)
	L506	Pt100 relay (3 pcs)
	L...	Refer to <i>ACS800 Ordering Information</i> (EN code: 64556568).
Fieldbus	K...	Refer to <i>ACS800 Ordering Information</i> (EN code: 64556568).
Control program	N...	
Language of manual	R...	

Type code selections for the ACS800-U2		
Selection	Alternatives	
Specialities	P901	coated boards
	P904	extended warranty

Main circuit and control

Diagram

This diagram shows the control interfaces and the main circuit of the drive.

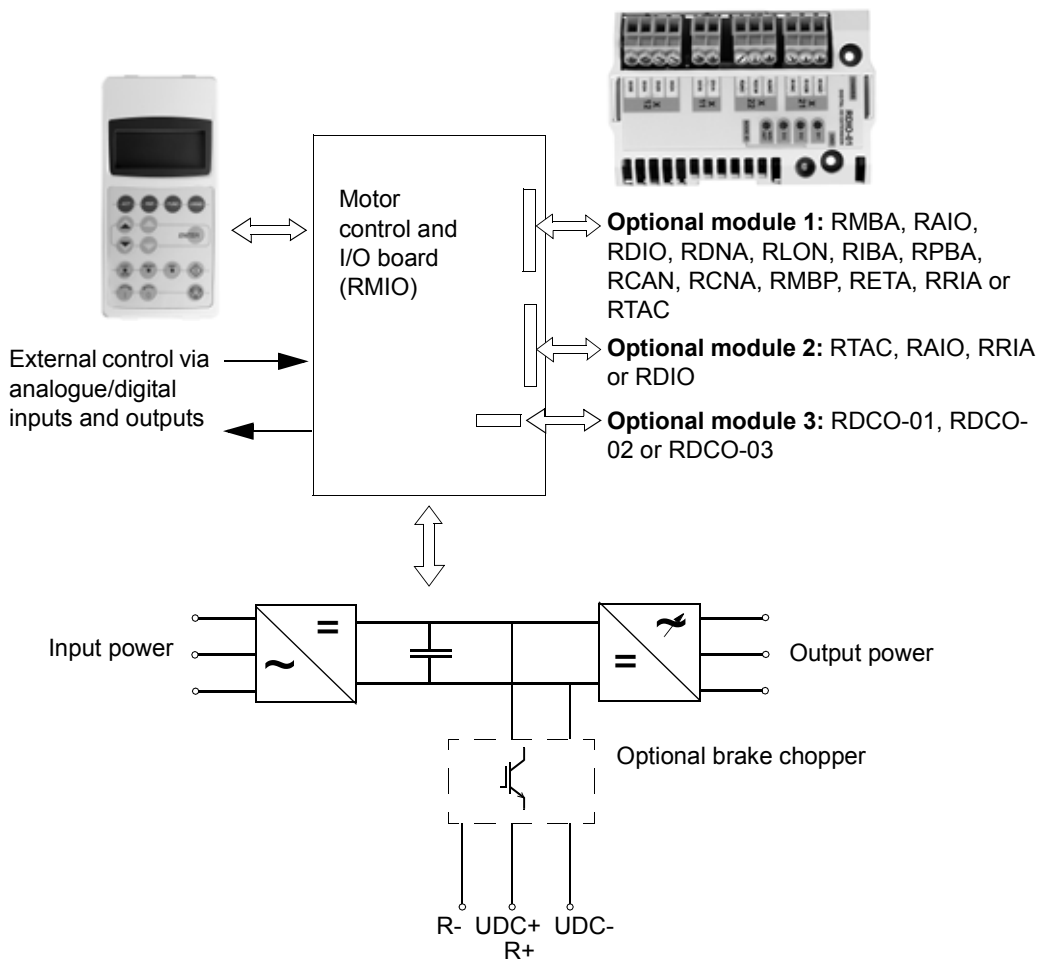

Operation

This table describes the operation of the main circuit in short.

Component	Description
six-pulse rectifier	converts the three-phase AC voltage to DC voltage
capacitor bank	energy storage which stabilizes the intermediate circuit DC voltage
six-pulse IGBT inverter	converts the DC voltage to AC voltage and vice versa. The motor operation is controlled by switching the IGBTs.

Printed circuit boards

The drive contains the following printed circuit boards as standard:

- main circuit board (AINT)
- motor control and I/O board (RMIO-02) with a fibre optic link to the AINT board
- input bridge control board (AINP)
- input bridge protection board (AIBP) which includes varistors, snubbers for the thyristors
- power supply board (APOW)
- gate driver control board (AGDR)
- diagnostics and panel interface board (ADPI)
- EMC filter boards (NRFC) with option +E202 in units with enclosure extension
- brake chopper control board (ABRC) with option +D150

Motor control

The motor control is based on the Direct Torque Control (DTC) method. Two phase currents and DC link voltage are measured and used for the control. The third phase current is measured for earth fault protection.

Planning the electrical installation

What this chapter contains

This chapter contains the instructions that you must follow when selecting the motor, cables, protections, cable routing and way of operation for the drive system.

Note: The installation must always be designed and made according to applicable local laws and regulations. ABB does not assume any liability whatsoever for any installation which breaches the local laws and/or other regulations. Furthermore, if the recommendations given by ABB are not followed, the drive may experience problems that the warranty does not cover.

To which products this chapter applies

This chapter applies to the ACS800-01/U1, ACS800-11/U11, ACS800-31/U31, ACS800-02/U2, ACS800-04/U4, and ACS800-07/U7 types up to -0610-x.

Note: All options described in this chapter are not available for all products. Check the availability from section *Type code* on page [24](#).

Motor selection and compatibility

1. Select the motor according to the rating tables in chapter *Technical Data*. Use the DriveSize PC tool if the default load cycles are not applicable.
2. Check that the motor ratings lie within the allowed ranges of the drive control program:
 - motor nominal voltage is $1/2 \dots 2 \cdot U_N$ of the drive
 - motor nominal current is $1/6 \dots 2 \cdot I_{2hd}$ of the drive in DTC control and $0 \dots 2 \cdot I_{2hd}$ in scalar control. The control mode is selected by a drive parameter.

3. Check that the motor voltage rating meets the application requirements:

If the drive is equipped with and then the motor voltage rating should be ...
diode supply ACS800-01, -U1, -02, -U2, -04, -04M, -U4 -07, -U7	no resistor braking is in use	U_N
	frequent or long term brake cycles will be used	U_{ACeq1}
IGBT supply ACS800-11, -U11, -31, -U31, -17, -37	DC link voltage will not be increased from nominal (parameter setting)	U_N
	DC link voltage will be increased from nominal (parameter setting)	U_{ACeq2}

U_N = rated input voltage of the drive

$U_{ACeq1} = U_{DC}/1.35$

$U_{ACeq2} = U_{DC}/1.41$

U_{ACeq} is the equivalent AC power source voltage of the drive in V AC.

U_{DC} is the maximum DC link voltage of the drive in V DC.

For resistor braking: $U_{DC} = 1.21 \times$ nominal DC link voltage.

For units with IGBT supply: See the parameter value.

(**Note:** Nominal DC link voltage is $U_N \times 1.35$ or $U_N \times 1.41$ in V DC.)

See notes 6 and 7 below the [Requirements table](#), page 34.

- Consult the motor manufacturer before using a motor in a drive system where the motor nominal voltage differs from the AC power source voltage.
- Ensure that the motor insulation system withstands the maximum peak voltage in the motor terminals. See the [Requirements table](#) below for the required motor insulation system and drive filtering.

Example 1: When the supply voltage is 440 V and a drive with a diode supply is operating in motor mode only, the maximum peak voltage in the motor terminals can be approximated as follows: $440 \text{ V} \cdot 1.35 \cdot 2 = 1190 \text{ V}$. Check that the motor insulation system withstands this voltage.

Example 2: When the supply voltage is 440 V and the drive is equipped with an IGBT supply, the maximum peak voltage in the motor terminals can be approximated as follows: $440 \text{ V} \cdot 1.41 \cdot 2 = 1241 \text{ V}$. Check that the motor insulation system withstands this voltage.

Protecting the motor insulation and bearings

The output of the drive comprises – regardless of output frequency – pulses of approximately 1.35 times the equivalent mains network voltage with a very short rise time. This is the case with all drives employing modern IGBT inverter technology.

The voltage of the pulses can be almost double at the motor terminals, depending on the attenuation and reflection properties of the motor cable and the terminals. This in turn can cause additional stress on the motor and motor cable insulation.

Modern variable speed drives with their fast rising voltage pulses and high switching frequencies can generate current pulses that flow through the motor bearings, which can gradually erode the bearing races and rolling elements.

The stress on motor insulation can be avoided by using optional ABB du/dt filters. du/dt filters also reduce bearing currents.

To avoid damage to motor bearings, the cables must be selected and installed according to the instructions given in the hardware manual. In addition, insulated N-end (non-drive end) bearings and output filters from ABB must be used according to the following table. Two types of filters are used individually or in combinations:

- optional du/dt filter (protects motor insulation system and reduces bearing currents).
- common mode filter (mainly reduces bearing currents).

Requirements table

The following table shows how to select the motor insulation system and when an optional ABB du/dt filter, insulated N-end (non-drive end) motor bearings and ABB common mode filters are required. The motor manufacturer should be consulted regarding the construction of the motor insulation and additional requirements for explosion-safe (EX) motors. Failure of the motor to fulfil the following requirements or improper installation may shorten motor life or damage the motor bearings and voids the warranty.

Manufacturer	Motor type	Nominal mains voltage (AC line voltage)	Requirement for			
			Motor insulation system	ABB du/dt filter, insulated N-end bearing and ABB common mode filter		
				$P_N < 100 \text{ kW}$ and frame size < IEC 315	$100 \text{ kW} \leq P_N < 350 \text{ kW}$ or frame size \geq IEC 315	$P_N \geq 350 \text{ kW}$ or frame size \geq IEC 400
			$P_N < 134 \text{ HP}$ and frame size < NEMA 500	$134 \text{ HP} \leq P_N < 469 \text{ HP}$ or frame size \geq NEMA 500	$P_N \geq 469 \text{ HP}$ or frame size > NEMA 580	
A B B	Random-wound M2_ and M3_	$U_N \leq 500 \text{ V}$	Standard	-	+ N	+ N + CMF
		$500 \text{ V} < U_N \leq 600 \text{ V}$	Standard	+ du/dt	+ du/dt + N	+ du/dt + N + CMF
			or Reinforced	-	+ N	+ N + CMF
		$600 \text{ V} < U_N \leq 690 \text{ V}$	Reinforced	+ du/dt	+ du/dt + N	+ du/dt + N + CMF
	Form-wound HX_ and AM_	$380 \text{ V} < U_N \leq 690 \text{ V}$	Standard	n.a.	+ N + CMF	$P_N < 500 \text{ kW}$: + N + CMF
						$P_N \geq 500 \text{ kW}$: + N + CMF + du/dt
	Old* form-wound HX_ and modular	$380 \text{ V} < U_N \leq 690 \text{ V}$	Check with the motor manufacturer.	+ du/dt with voltages over 500 V + N + CMF		
Random-wound HX_ and AM_ **	$0 \text{ V} < U_N \leq 500 \text{ V}$	Enamelled wire with fibre glass taping	+ N + CMF			
	$500 \text{ V} < U_N \leq 690 \text{ V}$		+ du/dt + N + CMF			

Manufacturer	Motor type	Nominal mains voltage (AC line voltage)	Requirement for			
			Motor insulation system	ABB du/dt filter, insulated N-end bearing and ABB common mode filter		
				$P_N < 100 \text{ kW}$ and frame size < IEC 315	$100 \text{ kW} \leq P_N < 350 \text{ kW}$ or frame size \geq IEC 315	$P_N \geq 350 \text{ kW}$ or frame size \geq IEC 400
			$P_N < 134 \text{ HP}$ and frame size < NEMA 500	$134 \text{ HP} \leq P_N < 469 \text{ HP}$ or frame size \geq NEMA 500	$P_N \geq 469 \text{ HP}$ or frame size > NEMA 580	
N O N - A B B	Random-wound and form-wound	$U_N \leq 420 \text{ V}$	Standard: $\hat{U}_{LL} = 1300 \text{ V}$	-	+ N or CMF	+ N + CMF
		$420 \text{ V} < U_N \leq 500 \text{ V}$	Standard: $\hat{U}_{LL} = 1300 \text{ V}$	+ du/dt	+ du/dt + N	+ du/dt + N + CMF
				or	+ du/dt + CMF	
				or		
		$500 \text{ V} < U_N \leq 600 \text{ V}$	Reinforced: $\hat{U}_{LL} = 1600 \text{ V}$	-	+ N or CMF	+ N + CMF
				+ du/dt	+ du/dt + N	+ du/dt + N + CMF
				or	+ du/dt + CMF	
				or		
		$600 \text{ V} < U_N \leq 690 \text{ V}$	Reinforced: $\hat{U}_{LL} = 1800 \text{ V}$	-	+ N or CMF	+ N + CMF
				+ du/dt	+ du/dt + N	+ du/dt + N + CMF
Reinforced: $\hat{U}_{LL} = 2000 \text{ V}$, 0.3 microsecond rise time ***	-			N + CMF	N + CMF	

* manufactured before 1.1.1998

** For motors manufactured before 1.1.1998, check for additional instructions with the motor manufacturer.

*** If the intermediate DC circuit voltage of the drive is increased from the nominal level by resistor braking or by the IGBT Supply Control Program (parameter selectable function), check with the motor manufacturer if additional output filters are needed in the applied drive operation range.

Note 1: The abbreviations used in the table are defined below.

Abbreviation	Definition
U_N	nominal voltage of the supply network
\hat{U}_{LL}	peak line-to-line voltage at motor terminals which the motor insulation must withstand
P_N	motor nominal power
du/dt	du/dt filter at the output of the drive +E205
CMF	common mode filter +E208
N	N-end bearing: insulated motor non-drive end bearing
n.a.	Motors of this power range are not available as standard units. Consult the motor manufacturer.

Note 2: Explosion-safe (EX) motors

The motor manufacturer should be consulted regarding the construction of the motor insulation and additional requirements for explosion-safe (EX) motors.

Note 3: High-output motors and IP 23 motors

For motors with higher rated output than what is stated for the particular frame size in EN 50347 (2001) and for IP 23 motors, the requirements of ABB random-wound motor series M3AA, M3AP, M3BP are given below. For other motor types, see the [Requirements table](#) above. Apply the requirements of range $100 \text{ kW} < P_N < 350 \text{ kW}$ to motors with $P_N < 100 \text{ kW}$. Apply the requirements of range $P_N \geq 350 \text{ kW}$ to motors within the range $100 \text{ kW} < P_N < 350 \text{ kW}$. In other cases, consult the motor manufacturer.

Manufacturer	Motor type	Nominal mains voltage (AC line voltage)	Requirement for			
			Motor insulation system	ABB du/dt filter, insulated N-end bearing and ABB common mode filter		
				$P_N < 55 \text{ kW}$	$55 \text{ kW} \leq P_N < 200 \text{ kW}$	$P_N \geq 200 \text{ kW}$
				$P_N < 74 \text{ HP}$	$74 \text{ HP} \leq P_N < 268 \text{ HP}$	$P_N \geq 268 \text{ HP}$
A B B	Random-wound M3AA, M3AP, M3BP	$U_N \leq 500 \text{ V}$	Standard	-	+ N	+ N + CMF
		$500 \text{ V} < U_N \leq 600 \text{ V}$	Standard	+ du/dt	+ du/dt + N	+ du/dt + N + CMF
			or			
			Reinforced	-	+ N	+ N + CMF
	$600 \text{ V} < U_N \leq 690 \text{ V}$	Reinforced	+ du/dt	+ du/dt + N	+ du/dt + N + CMF	

Note 4: HXR and AMA motors

All AMA machines (manufactured in Helsinki) for drive systems have form-wound windings. All HXR machines manufactured in Helsinki starting 1.1.1998 have form-wound windings.

Note 5: ABB motors of types other than M2_, M3_, HX_ and AM_

Use the selection criteria given for non-ABB motors.

Note 6: Resistor braking of the drive

When the drive is in braking mode for a large part of its operation time, the intermediate circuit DC voltage of the drive increases, the effect being similar to increasing the supply voltage by up to 20 percent. The voltage increase should be taken into consideration when determining the motor insulation requirement.

Example: Motor insulation requirement for a 400 V application must be selected as if the drive were supplied with 480 V.

Note 7: Drives with an IGBT supply unit

If voltage is raised by the drive (this is a parameter selectable function), select the motor insulation system according to the increased intermediate circuit DC voltage level, especially in the 500 V supply voltage range.

Note 8: Calculating the rise time and the peak line-to-line voltage

The peak line-to-line voltage at the motor terminals generated by the drive as well as the voltage rise time depend on the cable length. The requirements for the motor insulation system given in the table are "worst case" requirements covering installations with 30 metre and longer cables. The rise time can be calculated as follows: $\Delta t = 0.8 \cdot \hat{U}_{LL}/(du/dt)$. Read \hat{U}_{LL} and du/dt from the diagrams below. Multiply the values of the graph by the supply voltage (U_N). In case of drives with an IGBT supply unit or resistor braking, the \hat{U}_{LL} and du/dt values are approximately 20% higher.

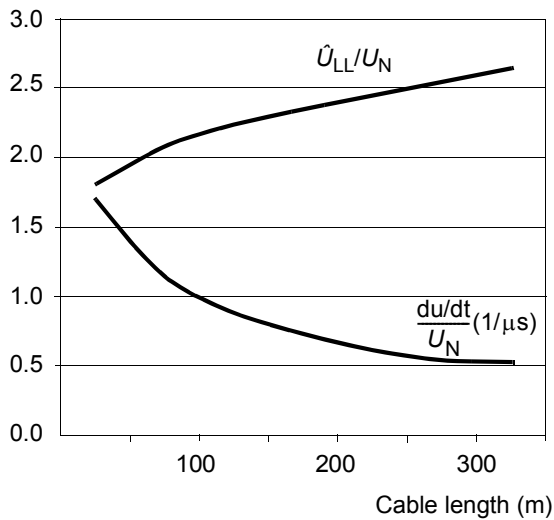

With du/dt Filter

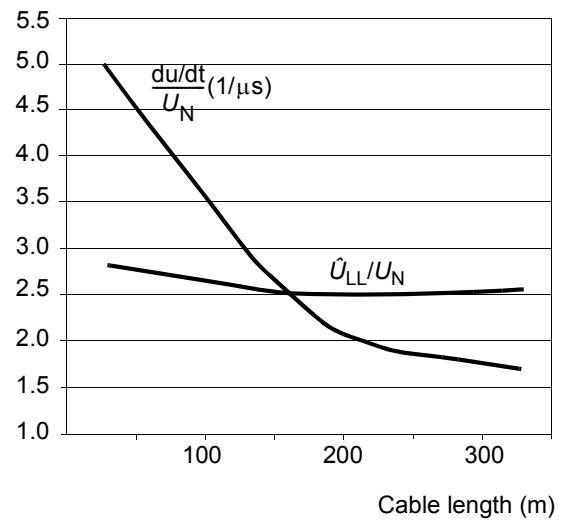

Without du/dt Filter

Note 9: Sine filters protect the motor insulation system. Therefore, du/dt filter can be replaced with a sine filter. The peak phase-to-phase voltage with the sine filter is approximately $1.5 \times U_N$.

Note 10: Common mode filter is available as a plus code option (+E208) or as a separate kit (one box including three rings for one cable).

Permanent magnet synchronous motor

Only one permanent magnet motor can be connected to the inverter output.

It is recommended to install a safety switch between the permanent magnet synchronous motor and the drive output. The switch is needed to isolate the motor during any maintenance work on the drive.

Supply connection

Disconnecting device (disconnecting means)

ACS800-01, ACS800-U1, ACS800-11, ACS800-U11, ACS800-31, ACS800-U31, ACS800-02 and ACS800-U2 without enclosure extension, ACS800-04, ACS800-U4

Install a hand-operated input disconnecting device (disconnecting means) between the AC power source and the drive. The disconnecting device must be of a type that can be locked to the open position for installation and maintenance work.

ACS800-02 and ACS800-U2 with enclosure extension, ACS800-07 and ACS800-U7

These units are equipped with a hand-operated input disconnecting device (disconnecting means) which isolates the drive and the motor from the AC power as standard. The disconnecting device does not, however, isolate the input busbars from the AC power. Therefore, during installation and maintenance work on the drive, the input cables and busbars must be isolated from the input power with a disconnecter at the distribution board or at the supplying transformer.

EU

To meet the European Union Directives, according to standard EN 60204-1, Safety of Machinery, the disconnecting device must be one of the following types:

- switch-disconnector of utilization category AC-23B (EN 60947-3)
- disconnector that has an auxiliary contact that in all cases causes switching devices to break the load circuit before the opening of the main contacts of the disconnector (EN 60947-3)
- circuit breaker suitable for isolation in accordance with EN 60947-2.

US

The disconnecting means must conform to the applicable safety regulations.

Fuses

See section [Thermal overload and short-circuit protection](#).

Main contactor

If used, dimension the contactor according to the nominal voltage and current of the drive. The utilization category (IEC 947-4) is AC-1.

Thermal overload and short-circuit protection

Thermal overload protection of the drive and the input and motor cables

The drive protects itself and the input and motor cables against thermal overload when the cables are dimensioned according to the nominal current of the drive. No additional thermal protection devices are needed.



WARNING! If the drive is connected to multiple motors, a separate thermal overload switch or a circuit breaker must be used for protecting each cable and motor. These devices may require a separate fuse to cut off the short-circuit current.

Thermal overload protection of the motor

According to regulations, the motor must be protected against thermal overload and the current must be switched off when overload is detected. The drive includes a motor thermal protection function that protects the motor and switches off the current when necessary. Depending on a drive parameter value, the function either monitors a calculated temperature value (based on a motor thermal model) or an actual temperature indication given by motor temperature sensors. The user can tune the thermal model further by feeding in additional motor and load data.

The most common temperature sensors are:

- motor sizes IEC180...225: thermal switch (e.g. Klixon)
- motor sizes IEC200...250 and larger: PTC or Pt100.

See the firmware manual for more information on the motor thermal protection, and the connection and use of the temperature sensors.

Protection against short-circuit in the motor cable

The drive protects the motor cable and motor in a short-circuit situation when the motor cable is dimensioned according to the nominal current of the drive. No additional protection devices are needed.

Protection against short-circuit inside the drive or in the supply cable

Arrange the protection according to the following guide lines.

Circuit diagram	Drive type	Short-circuit protection
DRIVE IS NOT EQUIPPED WITH INPUT FUSES		
<p>Distribution board Input cable Drive or drive module</p> <p>1) Fuse on input cable</p> <p>2) Fuse on input cable</p>	<p>ACS800-01 ACS800-U1 ACS800-02 ACS800-U2+0C111 ACS800-11 ACS800-U11 ACS800-31 ACS800-U31 ACS800-04 ACS800-U4</p>	<p>Protect the drive and input cable with fuses or a circuit breaker. See footnotes 1) and 2).</p>
DRIVE IS EQUIPPED WITH INPUT FUSES		
<p>Distribution board Input cable Drive</p> <p>3) Fuse on input cable</p> <p>4) Fuse inside drive</p>	<p>ACS800-02+C111 ACS800-U2 ACS800-07 ACS800-U7</p>	<p>Protect the input cable with fuses or a circuit breaker according to local regulations. See footnotes 3) and 4).</p>

- 1) Size the fuses according to instructions given in chapter *Technical data*. The fuses will protect the input cable in short-circuit situations, restrict drive damage and prevent damage to adjoining equipment in case of a short-circuit inside the drive.

- 2) Circuit breakers which have been tested by ABB with the ACS800 can be used. Fuses must be used with other circuit breakers. Contact your local ABB representative for the approved breaker types and supply network characteristics.

The protective characteristics of circuit breakers depend on the type, construction and settings of the breakers. There are also limitations pertaining to the short-circuit capacity of the supply network.



WARNING! Due to the inherent operating principle and construction of circuit breakers, independent of the manufacturer, hot ionized gases may escape from the breaker enclosure in case of a short-circuit. To ensure safe use, special attention must be paid to the installation and placement of the breakers. Follow the manufacturer's instructions.

Note: Circuit breakers must not be used without fuses in the USA.

- 3) Size the fuses according to local safety regulations, appropriate input voltage and the rated current of the drive (see chapter *Technical data*).
- 4) ACS800-02 units and ACS800-07 units with enclosure extension are equipped with aR fuses as standard. ACS800-U2 and ACS800-U7 units are equipped with T/L fuses as standard. The fuses restrict drive damage and prevent damage to adjoining equipment in case of a short-circuit inside the drive.

Ground fault protection

The drive is equipped with an internal ground fault protective function to protect the unit against ground faults in the motor and motor cable. This is not a personal safety or a fire protection feature. The ground fault protective function can be disabled with a parameter, refer to the appropriate *ACS800 Firmware Manual*.

The EMC filter of the drive includes capacitors connected between the main circuit and the frame. These capacitors and long motor cables increase the ground leakage current and may cause fault current circuit breakers to function.

Emergency stop devices

For safety reasons, install the emergency stop devices at each operator control station and at other operating stations where emergency stop may be needed.

Note: Pressing the stop key (⏏) on the control panel of the drive does not generate an emergency stop of the motor or separate the drive from dangerous potential.

ACS800-02/U2 with enclosure extension and ACS800-07/U7

An emergency stop function is optionally available for stopping and switching off the whole drive. Two stop categories according to IEC/EN 60204-1 (1997) are available: immediate removal of power (Category 0 for ACS800-02/U2 and ACS800-07/U7) and controlled emergency stop (Category 1 for ACS800-07/U7).

Restarting after an emergency stop

After an emergency stop, the emergency stop button must be released and the drive started by turning the operating switch of the drive from position "ON" to "START".

Power-loss ride-through function

The power-loss ride-through function is activated when parameter 20.06 UNDERVOLTAGE CTRL is set to ON (default in Standard Control Program).

ACS800-07/U7 units without line contactor

The power-loss ride-through function is not in use.

ACS800-07/U7 units with line contactor (+F250)

The power-loss ride-through function is enabled by connecting RMIO board terminals X22:8 and X22:11 with a jumper.

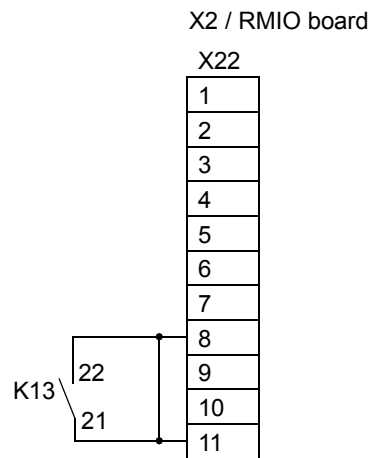

Prevention of Unexpected Start

The ACS800-01/U1, ACS800-04/U4, ACS800-11/U11, ACS800-31/U31 and ACS800-07/U7 can be equipped with an optional Prevention of Unexpected Start function according to standards IEC/EN 60204-1: 1997; ISO/DIS 14118: 2000 and EN 1037: 1996.

The Prevention of Unexpected Start function disables the control voltage of the power semiconductors, thus preventing the inverter from generating the AC voltage required to rotate the motor. By using this function, short-time operations (like cleaning) and/or maintenance work on non-electrical parts of the machinery can be performed without switching off the AC power supply to the drive.

The operator activates the Prevention of Unexpected Start function by opening a switch on a control desk. An indicating lamp on the control desk will light, signalling that the prevention is active. The switch can be locked out.

The user must install on a control desk near the machinery:

- switching/disconnecting device for the circuitry. "Means shall be provided to prevent inadvertent, and/or mistaken closure of the disconnecting device." EN 60204-1: 1997.
- indicating lamp; on = starting the drive is prevented, off = drive is operative.
- ACS800-01/U1, ACS800-04/U4, ACS800-11/U11, ACS800-31/U31: safety relay (type BD5935 has been approved by ABB)

For connections to the drive, see chapter *Installation of AGPS board (Prevention of Unexpected Start, +Q950)* or the circuit diagram delivered with the drive (ACS800-07/U7).



WARNING! The Prevention of Unexpected Start function does not disconnect the voltage of the main and auxiliary circuits from the drive. Therefore maintenance work on electrical parts of the drive or the motor can only be carried out after isolating the drive system from the main supply.

Note: If a running drive is stopped by using the Prevention of Unexpected Start function, the drive will cut off the motor supply voltage and the motor will coast to stop.

Selecting the power cables

General rules

Dimension the mains (input power) and motor cables **according to local regulations**:

- The cable must be able to carry the drive load current. See chapter *Technical data* for the rated currents.
- The cable must be rated for at least 70 °C maximum permissible temperature of conductor in continuous use. For US, see [Additional US requirements](#).
- The inductance and impedance of the PE conductor/cable (grounding wire) must be rated according to permissible touch voltage appearing under fault conditions (so that the fault point voltage will not rise excessively when a ground fault occurs).
- 600 V AC cable is accepted for up to 500 V AC. 750 V AC cable is accepted for up to 600 V AC. For 690 V AC rated equipment, the rated voltage between the conductors of the cable should be at least 1 kV.

For drive frame size R5 and larger, or motors larger than 30 kW (40 HP), symmetrical shielded motor cable must be used (figure below). A four-conductor system can be used up to frame size R4 with up to 30 kW (40 HP) motors, but shielded symmetrical motor cable is always recommended. The shield(s) of motor cable(s) must have 360° bonding at both ends.

Note: When continuous metal conduit is employed, shielded cable is not required. The conduit must have bonding at both ends as with cable shield.

A four-conductor system is allowed for input cabling, but shielded symmetrical cable is recommended. To operate as a protective conductor, the shield conductivity must be as follows when the protective conductor is made of the same metal as the phase conductors:

Cross-sectional area of the phase conductors S (mm ²)	Minimum cross-sectional area of the corresponding protective conductor S_p (mm ²)
$S \leq 16$	S
$16 < S \leq 35$	16
$35 < S$	$S/2$

Compared to a four-conductor system, the use of symmetrical shielded cable reduces electromagnetic emission of the whole drive system as well as the stress on motor insulation, bearing currents and wear.

The motor cable and its PE pigtail (twisted shield) should be kept as short as possible in order to reduce high-frequency electromagnetic emission, as well as stray currents outside the cable and capacitive current (relevant in power range below 20 kW).

Alternative power cable types

Power cable types that can be used with the drive are represented below.

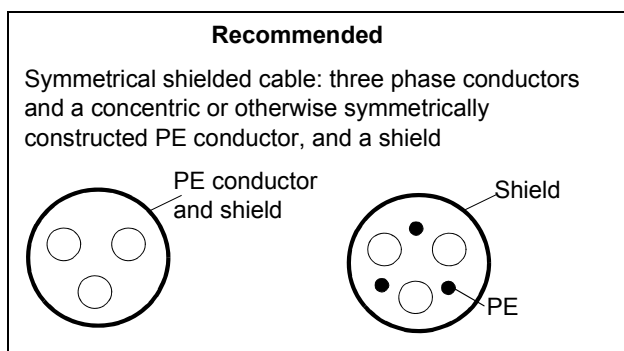

A separate PE conductor is required if the conductivity of the cable shield is $< 50\%$ of the conductivity of the phase conductor.

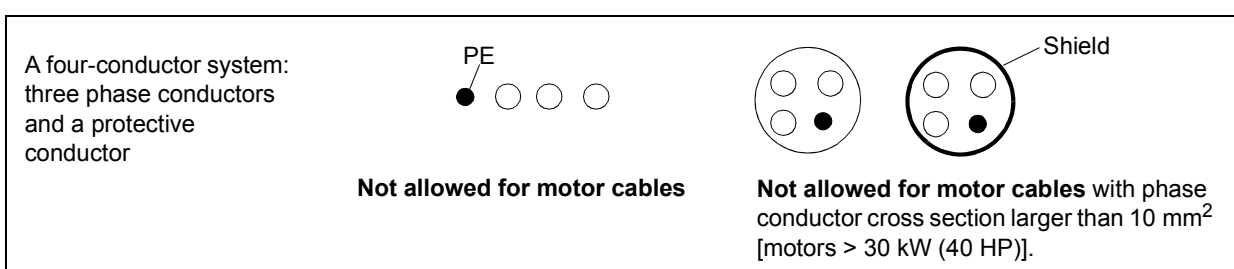
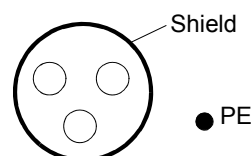

Motor cable shield

To effectively suppress radiated and conducted radio-frequency emissions, the shield conductivity must be at least $1/10$ of the phase conductor conductivity. The requirements are easily met with a copper or aluminium shield. The minimum requirement of the motor cable shield of the drive is shown below. It consists of a concentric layer of copper wires with an open helix of copper tape or copper wire. The better and tighter the shield, the lower the emission level and bearing currents.

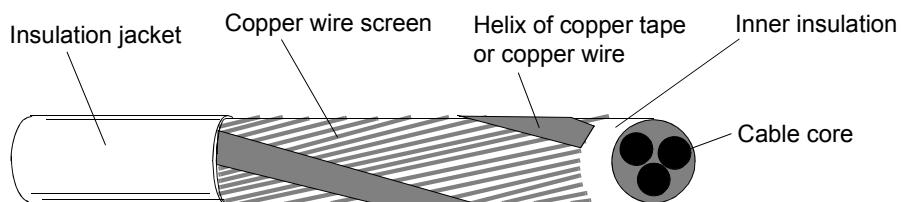

Additional US requirements

Type MC continuous corrugated aluminum armor cable with symmetrical grounds or shielded power cable must be used for the motor cables if metallic conduit is not used. For the North American market, 600 V AC cable is accepted for up to 500 V AC. 1000 V AC cable is required above 500 V AC (below 600 V AC). For drives rated over 100 amperes, the power cables must be rated for 75 °C (167 °F).

Conduit

Separate parts of a conduit must be coupled together, bridge the joints with a ground conductor bonded to the conduit on each side of the joint. Bond the conduits also to the drive enclosure and motor frame. Use separate conduits for input power, motor, brake resistor, and control wiring. When conduit is employed, type MC continuous corrugated aluminium armor cable or shielded cable is not required. A dedicated ground cable is always required.

Note: Do not run motor wiring from more than one drive in the same conduit.

Armored cable / shielded power cable

Six conductor (3 phases and 3 ground) type MC continuous corrugated aluminum armor cable with symmetrical grounds is available from the following suppliers (trade names in parentheses):

- Anixter Wire & Cable (Philsheath)
- BICC General Corp (Philsheath)
- Rockbestos Co. (Gardex)
- Oaknite (CLX).

Shielded power cables are available from Belden, LAPPKABEL (ÖLFLEX) and Pirelli.

Power factor compensation capacitors

Power factor compensation is not needed with AC drives. However, if a drive is to be connected in a system with compensation capacitors installed, note the following restrictions.



WARNING! Do not connect power factor compensation capacitors or harmonic filters to the motor cables (between the drive and the motor). They are not meant to be used with AC drives and can cause permanent damage to the drive or themselves.

If there are power factor compensation capacitors in parallel with the three phase input of the drive:

1. Do not connect a high-power capacitor to the power line while the drive is connected. The connection will cause voltage transients that may trip or even damage the drive.
2. If capacitor load is increased/decreased step by step when the AC drive is connected to the power line: Ensure that the connection steps are low enough not to cause voltage transients that would trip the drive.
3. Check that the power factor compensation unit is suitable for use in systems with AC drives i.e. harmonic generating loads. In such systems, the compensation unit should typically be equipped with a blocking reactor or harmonic filter.

Equipment connected to the motor cable

Installation of safety switches, contactors, connection boxes, etc.

To minimize the emission level when safety switches, contactors, connection boxes or similar equipment are installed in the motor cable between the drive and the motor:

- EU: Install the equipment in a metal enclosure with 360 degrees grounding for the shields of both the incoming and outgoing cable, or connect the shields of the cables otherwise together.
- US: Install the equipment in a metal enclosure in a way that the conduit or motor cable shielding runs consistently without breaks from the drive to the motor.

Bypass connection



WARNING! Never connect the supply power to the drive output terminals U2, V2 and W2. If frequent bypassing is required, employ mechanically connected switches or contactors. Mains (line) voltage applied to the output can result in permanent damage to the unit.

Before opening a contactor (DTC control mode selected)

Stop the drive and wait for the motor to stop before opening a contactor between the output of the drive and the motor when the DTC control mode is selected. See the appropriate ACS800 control program firmware manual for the required parameter settings. Otherwise, the contactor will be damaged. In scalar control, the contactor can be opened with the drive running.

Protecting the relay output contacts and attenuating disturbances in case of inductive loads

Inductive loads (relays, contactors, motors) cause voltage transients when switched off.

The relay contacts on the RMIO board are protected with varistors (250 V) against overvoltage peaks. In spite of this, it is highly recommended to equip inductive loads with noise attenuating circuits [varistors, RC filters (AC) or diodes (DC)] in order to minimize the EMC emission at switch-off. If not suppressed, the disturbances may connect capacitively or inductively to other conductors in the control cable and form a risk of malfunction in other parts of the system.

Install the protective component as close to the inductive load as possible. Do not install protective components at the RMIO board terminal block.

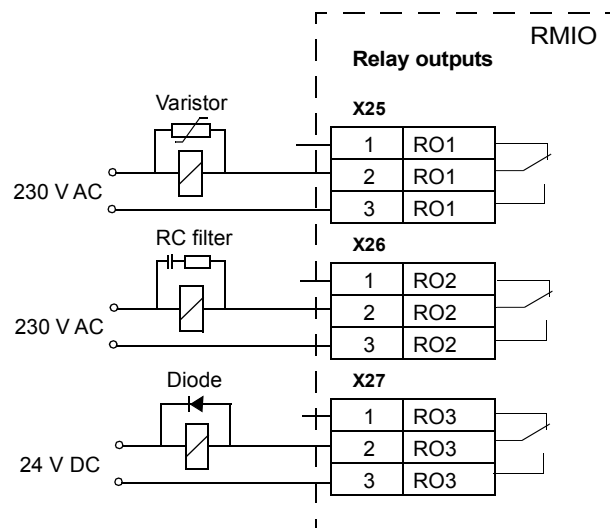

Selecting the control cables

All control cables must be shielded.

Use a double-shielded twisted pair cable (Figure a, e.g. JAMAK by NK Cables, Finland) for analogue signals. This type of cable is recommended for the pulse encoder signals also. Employ one individually shielded pair for each signal. Do not use common return for different analogue signals.

A double-shielded cable is the best alternative for low-voltage digital signals but single-shielded twisted pair cable (Figure b) is also usable.

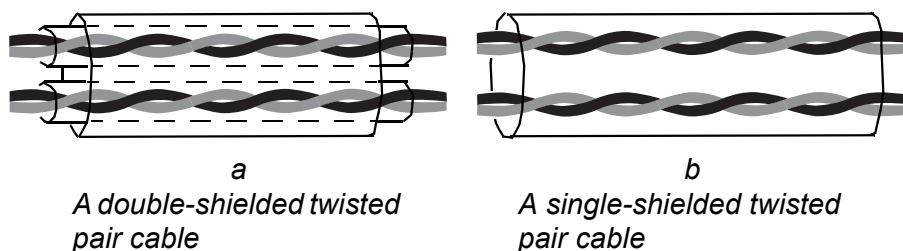

Run analogue and digital signals in separate, shielded cables.

Relay-controlled signals, providing their voltage does not exceed 48 V, can be run in the same cables as digital input signals. It is recommended that the relay-controlled signals be run as twisted pairs.

Never mix 24 VDC and 115/230 V AC signals in the same cable.

Relay cable

The cable type with braided metallic screen (e.g. ÖLFLEX by LAPPKABEL, Germany) has been tested and approved by ABB.

Control panel cable

In remote use, the cable connecting the control panel to the drive must not exceed 3 metres (10 ft). The cable type tested and approved by ABB is used in control panel option kits.

Connection of a motor temperature sensor to the drive I/O



WARNING! IEC 60664 requires double or reinforced insulation between live parts and the surface of accessible parts of electrical equipment which are either non-conductive or conductive but not connected to the protective earth.

To fulfil this requirement, the connection of a thermistor (and other similar components) to the digital inputs of the drive can be implemented in three alternate ways:

1. There is double or reinforced insulation between the thermistor and live parts of the motor.
 2. Circuits connected to all digital and analogue inputs of the drive are protected against contact and insulated with basic insulation (the same voltage level as the drive main circuit) from other low voltage circuits.
 3. An external thermistor relay is used. The insulation of the relay must be rated for the same voltage level as the main circuit of the drive. For connection, see *ACS800 Firmware Manual*.
-

Installation sites above 2000 metres (6562 feet)



WARNING! Protect against direct contact when installing, operating and servicing the RMIO board wiring and optional modules attached to the board. The Protective Extra Low Voltage (PELV) requirements stated in EN 50178 are not fulfilled at altitudes above 2000 m (6562 ft).

Routing the cables

Route the motor cable away from other cable routes. Motor cables of several drives can be run in parallel installed next to each other. It is recommended that the motor cable, input power cable and control cables be installed on separate trays. Avoid long parallel runs of motor cables with other cables in order to decrease electromagnetic interference caused by the rapid changes in the drive output voltage.

Where control cables must cross power cables make sure they are arranged at an angle as near to 90 degrees as possible. Do not run extra cables through the drive.

The cable trays must have good electrical bonding to each other and to the grounding electrodes. Aluminium tray systems can be used to improve local equalizing of potential.

A diagram of the cable routing is shown below.

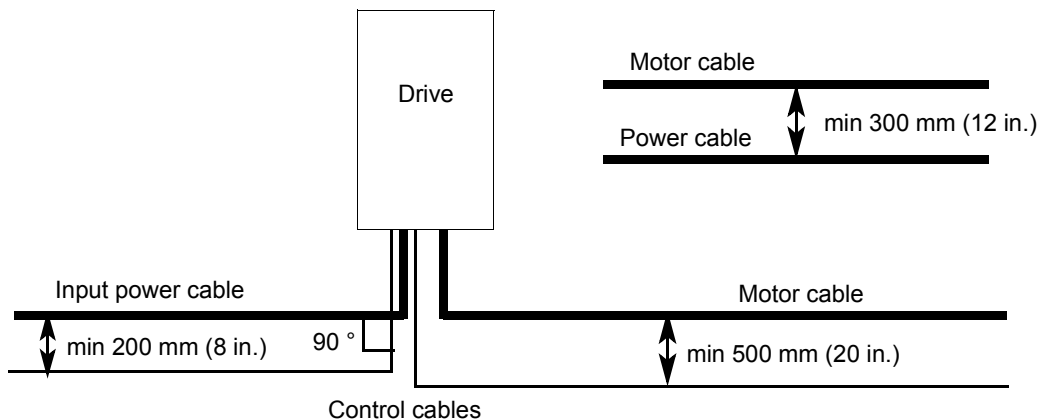

Control cable ducts

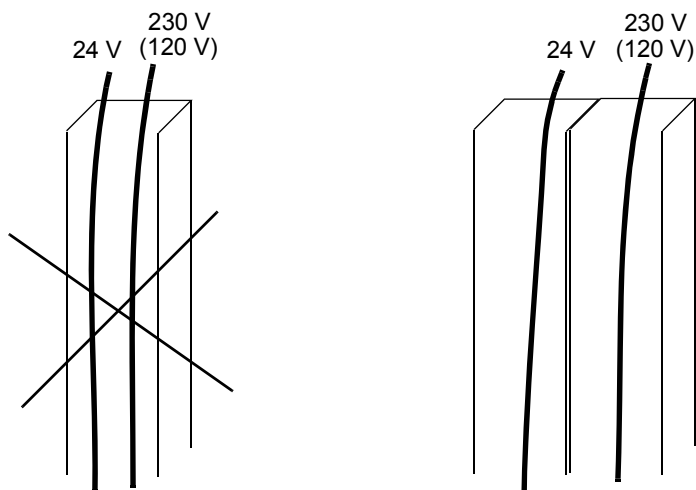

Not allowed unless the 24 V cable is insulated for 230 V (120 V) or insulated with an insulation sleeving for 230 V (120 V).

Lead 24 V and 230 V (120 V) control cables in separate ducts inside the cabinet.

Installation

What this chapter contains

This chapter describes the mechanical and electrical installation procedure of the drive.



WARNING! Only qualified electricians are allowed to carry out the work described in this chapter. Follow the *Safety instructions* on the first pages of this manual. Ignoring the safety instructions can cause injury or death.

Moving the unit

Move the transport package by pallet truck to the installation site. Unpack the package as shown below.



Lifting when the enclosure extension is included

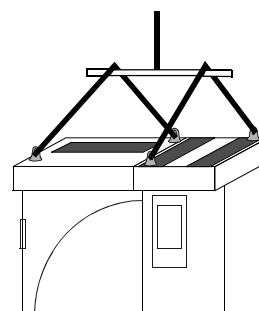



WARNING! The drive is heavy [frame size R7: 110 kg (220 lb), frame size R8: 240 kg (507 lb)]. Lift the drive by the upper part only using the lifting lugs attached to the top of the unit. The lower part will be deformed from lifting. Do not remove the pedestal before lifting.

Do not tilt the drive. The centre of gravity of the unit is high. The unit will overturn from a tilt of about 6 degrees.

Do not wheel the drive except for installation (the front direction is preferable because the front wheels are steadier). The drive frame may be deformed from wheeling when the pedestal is removed. If the drive is moved over long distances, place it on its back on a pallet and move it by fork-lift.

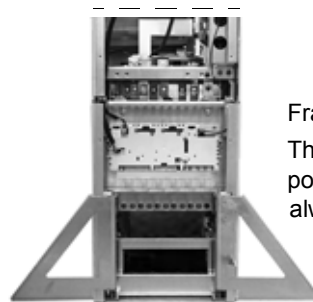
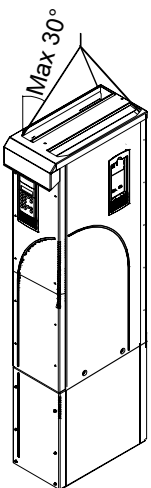

Frame size R8:

The support legs must be locked to open position during the installation and always when wheeling the unit.

Before installation

Delivery check

The drive is delivered in a box that also contains:

- hardware manual
- appropriate firmware manuals and guides
- optional module manuals
- delivery documents.

Check that there are no signs of damage. Before attempting installation and operation, check the information on the type designation label of the drive to verify that the unit is of the correct type. The label includes an IEC and NEMA rating, UL, C-UL, CSA and CE markings, a type code and a serial number, which allow individual recognition of each unit. The first digit of the serial number refers to the manufacturing plant. The next four digits refer to the unit's manufacturing year and week respectively. The remaining digits complete the serial number so that there are no two units with the same serial number.

The type designation label is located under the front visor and the serial number label inside the unit. Example labels are shown below.

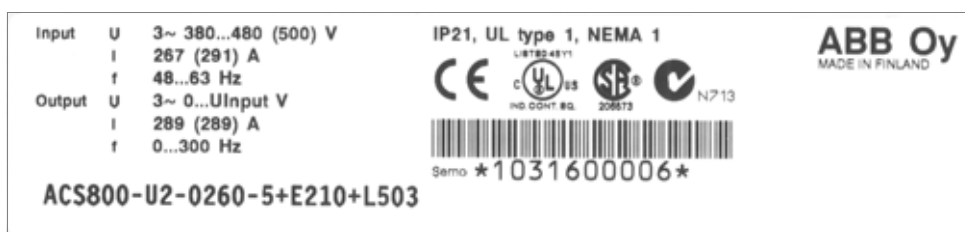

Type designation label



Serial number label

Requirements for the installation site

The drive must be installed in an upright position on floor (or wall). Check the installation site according to the requirements below. Refer to [Dimensional drawings](#) for frame details. See [Technical data](#) for the allowed operation conditions of the drive.

Wall

The wall/material near the unit must be of non-flammable material. Check that there is nothing on the wall to inhibit the installation.

If a unit is mounted on the wall, the wall must be as close to vertical as possible, and strong enough to carry the weight of the unit. The drive must not be installed without the pedestal and a support shelf on wall, refer to [ACS800-02/U2 Application Guide on Wall Mounting](#) [3AFE68250013 (English)].

Floor

The floor/material below the installation should be non-flammable. The floor must be horizontal.

Free space around the unit

See section *Installation procedure: Choose the mounting orientation (a, b, c or d)*.

Cooling air flow

Provide the drive with the amount of fresh cooling air given in [Technical data / IEC data](#) or [NEMA data](#).

The cooling air will enter the unit from the front air grating and flow upwards inside the unit. Recirculating cooling air into the unit is not allowed.

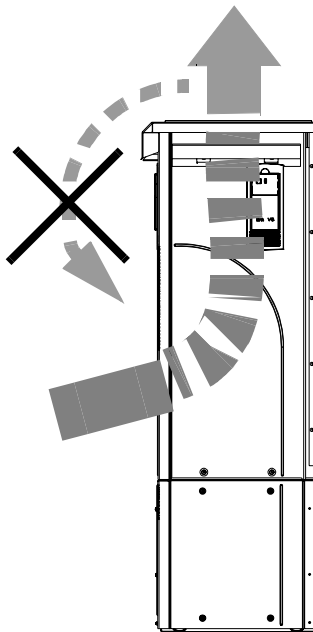

IT (ungrounded) systems

A drive equipped with no EMC filter or with EMC filter +E210 is suitable for IT (ungrounded systems). If the drive is equipped with EMC filter +E202, disconnect the filter before connecting the drive to an ungrounded system. For detailed instructions on how to do this, please contact your local ABB representative.



WARNING! If a drive with EMC filter +E202 is installed on an IT system [an ungrounded power system or a high resistance-grounded (over 30 ohms) power system], the system will be connected to earth potential through the EMC filter capacitors of the drive. This may cause danger or damage the unit.

Required tools

- set of screw drivers
- torque wrench with 500 mm (20 in.) or 2 x 250 mm (2 x 10 in.) extension bar
- 19 mm (3/4 in.) socket
for frame size R7: 13 mm (1/2 in.) magnetic end socket
for frame size R8: 17 mm (11/16 in.) magnetic end socket.

Checking the insulation of the installation

Drive

Every drive has been tested for insulation between the main circuit and the chassis (2500 V rms 50 Hz for 1 second) at the factory. Therefore, do not make any voltage tolerance or insulation resistance tests (e.g. hi-pot or megger) on any part of the drive.

Input cable

Check the insulation of the input cable according to local regulations before connecting it to the drive.

Motor and motor cable

Check the insulation of the motor and motor cable as follows:

1. Check that the motor cable is disconnected from the drive output terminals U2, V2 and W2.
2. Measure the insulation resistances of the motor cable and the motor between each phase and the Protective Earth by using a measuring voltage of 1 kV DC. The insulation resistance must be higher than 1 Mohm.

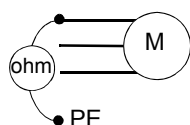

Power cable connection diagram

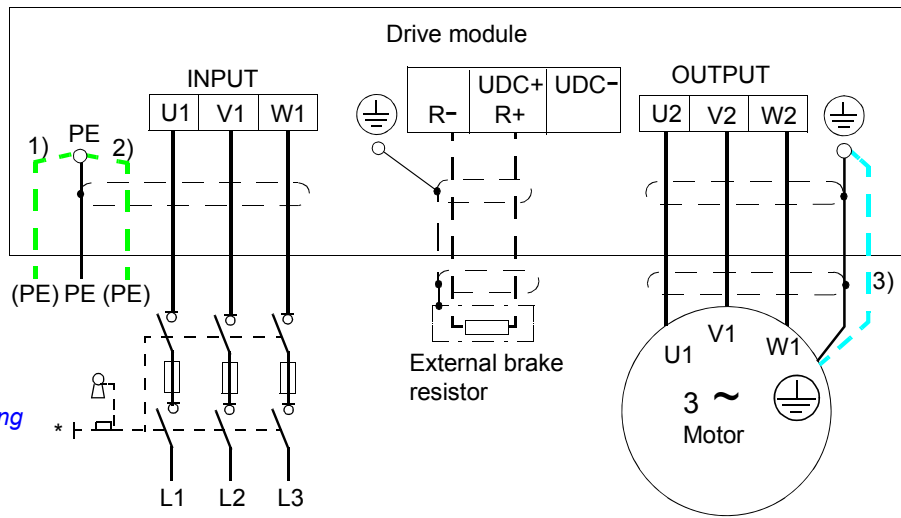

* For alternatives, see *Planning the electrical installation: Disconnecting device (disconnecting means)*

1), 2)

If shielded cable is used (not required but recommended), use a separate PE cable (1) or a cable with a grounding conductor (2) if the conductivity of the input cable shield is < 50 % of the conductivity of the phase conductor.

Ground the other end of the input cable shield or PE conductor at the distribution board.

3) Use a separate grounding cable if the conductivity of the cable shield is < 50 % of the conductivity of the phase conductor and there is no symmetrically constructed grounding conductor in the cable (see *Planning the electrical installation / Selecting the power cables*).

Note:

If there is a symmetrically constructed grounding conductor in the motor cable in addition to the conductive shield, connect the grounding conductor to the grounding terminal at the drive and motor ends.

Do not use an asymmetrically constructed motor cable. Connecting its fourth conductor at the motor end increases bearing currents and causes extra wear.

Grounding of the motor cable shield at the motor end

For minimum radio frequency interference:

- ground the cable shield 360 degrees at the lead-through of the motor terminal box

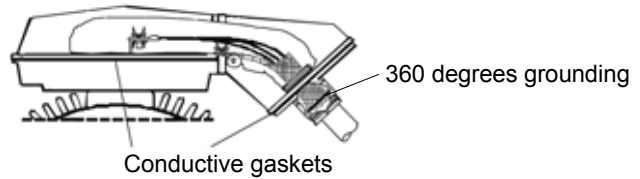

- or ground the cable by twisting the shield as follows: flattened width $\geq 1/5 \cdot \text{length}$.

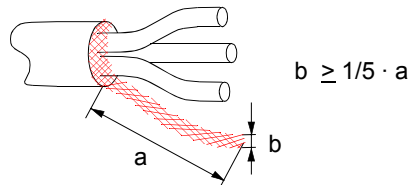

Installation procedure

Choose the mounting orientation (a, b, c or d)

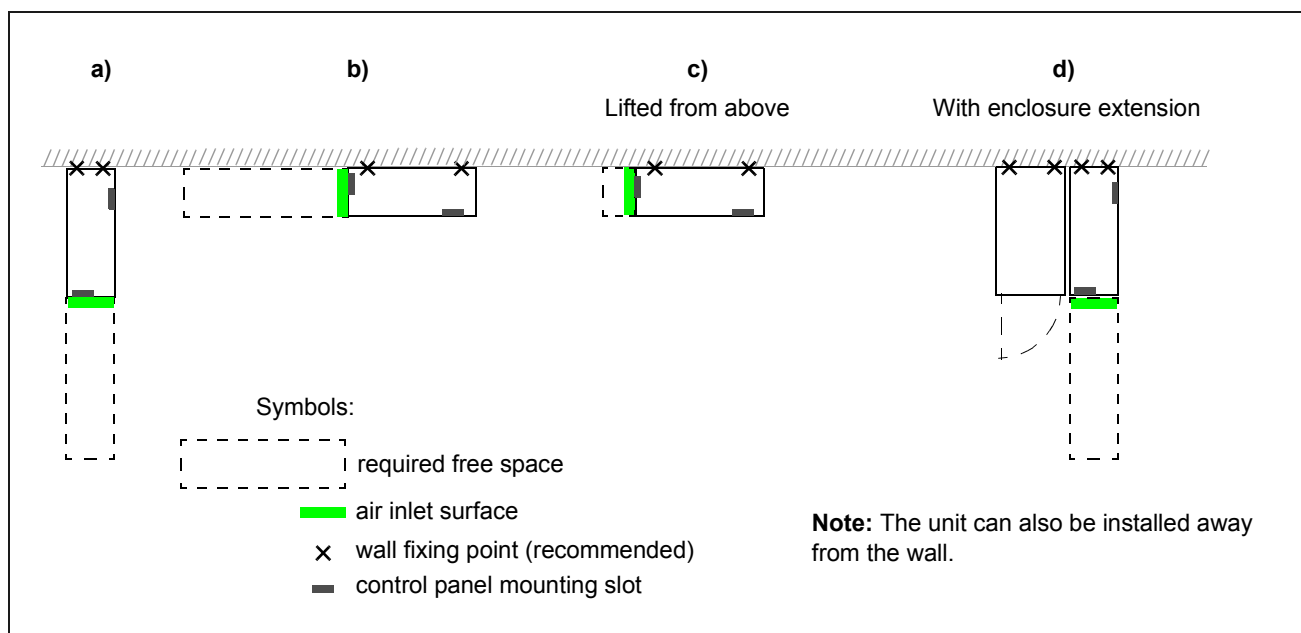

Frame size	Mounting orientation	Required free space around the unit for mounting, maintenance, service and cooling *					
		Front		Side		Above	
		mm	in.	mm	in.	mm	in.
R7	a, d	500	20	-	-	200	7.9
	b	-	-	500	20	200	7.9
	c	-	-	200**	7.9**	lifting space	lifting space
R8	a, d	600	24	-	-	300	12
	b	-	-	600	24	300	12
	c	-	-	300**	12**	lifting space	lifting space

* space for the installer not included

** space for fan and capacitor replacement not included

Mounting orientations a and b

Make holes in the wall (recommended):

1. Lift the unit against the wall into the mounting place.
2. Mark the locations for the two fixing points in the wall (not for mounting orientation a if the unit is subjected to sideways vibration).
3. Mark the bottom edges of the unit to the floor.

Remove the pedestal (frame size R7):

1. Remove the lower front covers by undoing the fixing screws.
2. Undo the red screws that fix the pedestal to the frame from front.
3. Undo the red M8 combi screws (8 pcs or 9 pcs with +D150) that connect the busbars of the pedestal to the upper frame. Use a torque wrench with an extension bar.
4. Wheel the drive frame out by using the handle.

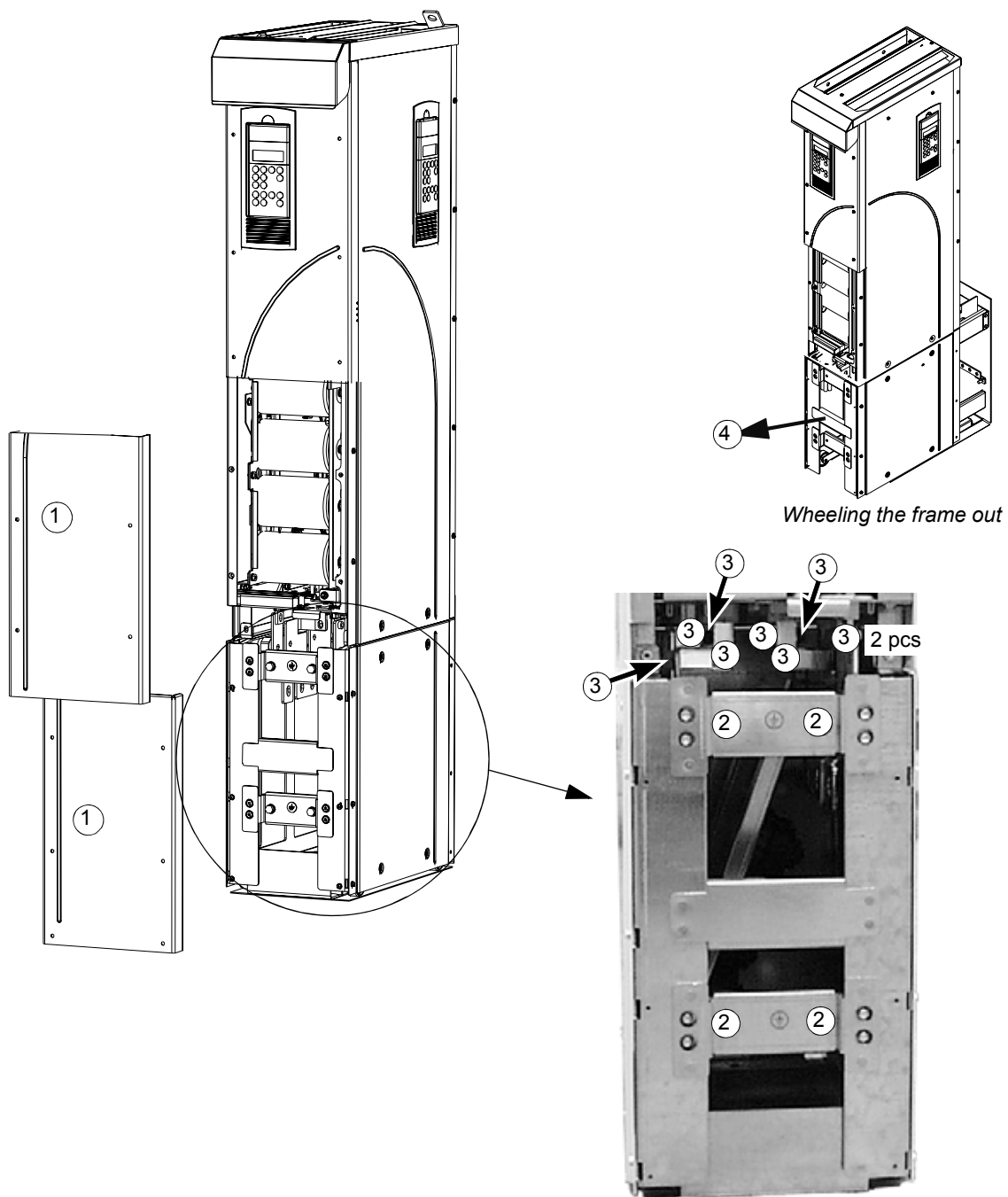

Remove the pedestal (frame size R8):

1. Remove the lower front covers by undoing the fixing screws.
2. Press the left support leg a little down and turn it left. Let it lock down. Turn the right leg aside in the same way. The legs will prevent the unit from falling down during the installation.
3. Undo the screws that fix the pedestal to the frame from front.
4. Undo the screws that connect the busbars of the pedestal to the upper frame. Use a torque wrench with an extension bar.
5. Wheel the drive frame out by using the handle.

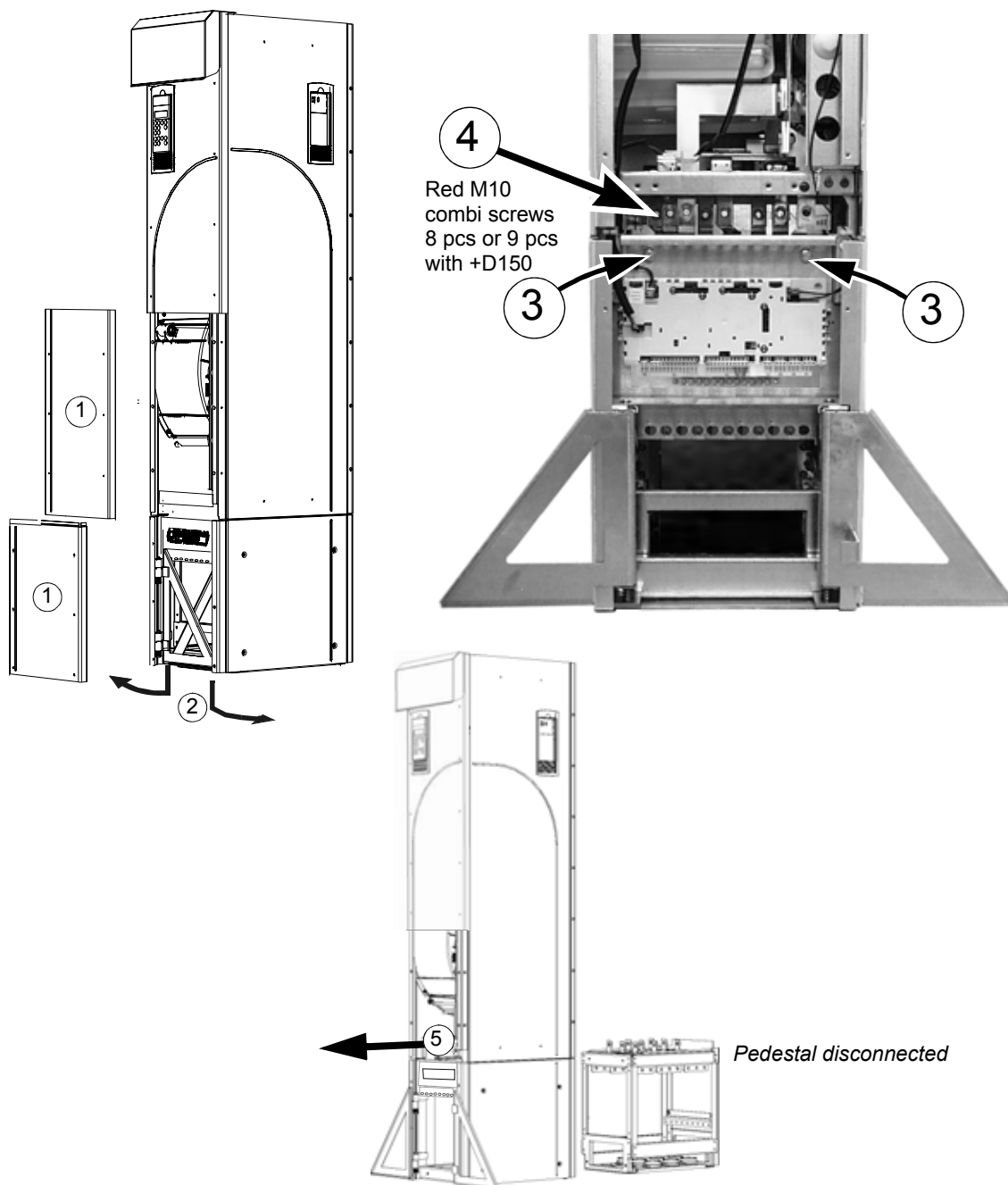

Fix the lead-through plate to the floor:

1. Make a hole in the floor or cable conduit cover below the lead-through plate. See [Dimensional drawings](#).
2. Check that the floor is horizontal with a spirit level.
3. Fasten the lead-through plate with screws or bolts.

Note: The screws/bolts will be removed and refastened when the pedestal is fastened through the same holes later on. The lead-through plate can be fastened after leading the cables through it if the cabling procedure is more convenient in that way.

Frame size R7

These brackets can be removed for the time of the installation

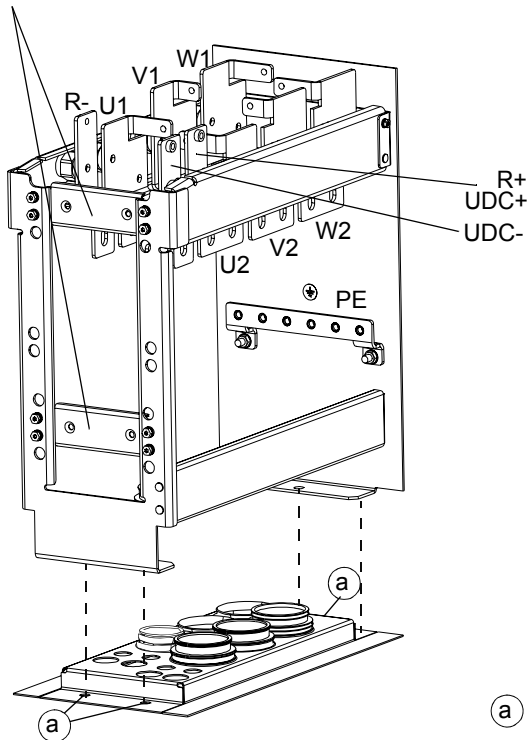

ProE: 64524739

Busbars connecting the power cable terminals to the drive module

Frame size R8

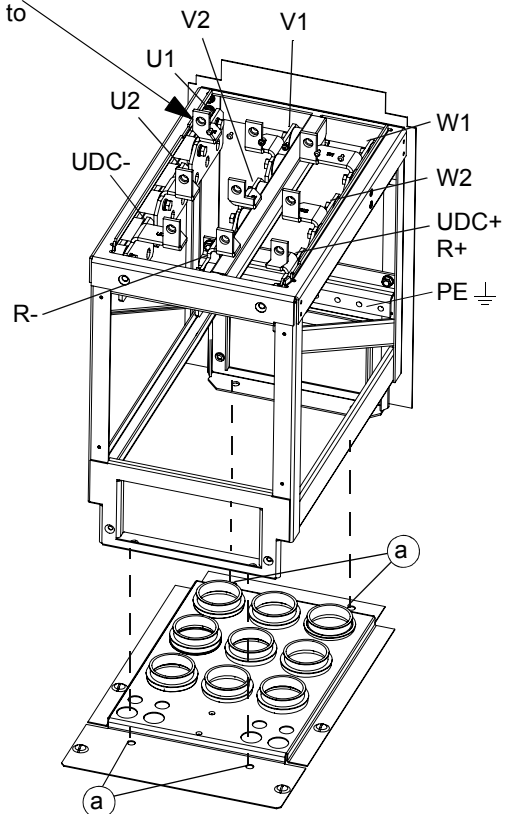

ProE: 64564439

(a) floor fixing points

Units with EMC screen (+E202)

Remove the EMC screen by undoing the five fastening screws.

Note: The screen must be replaced when the cables have been connected. Tightening torque of the fastening screws is 5 Nm (3.7 lbf ft).

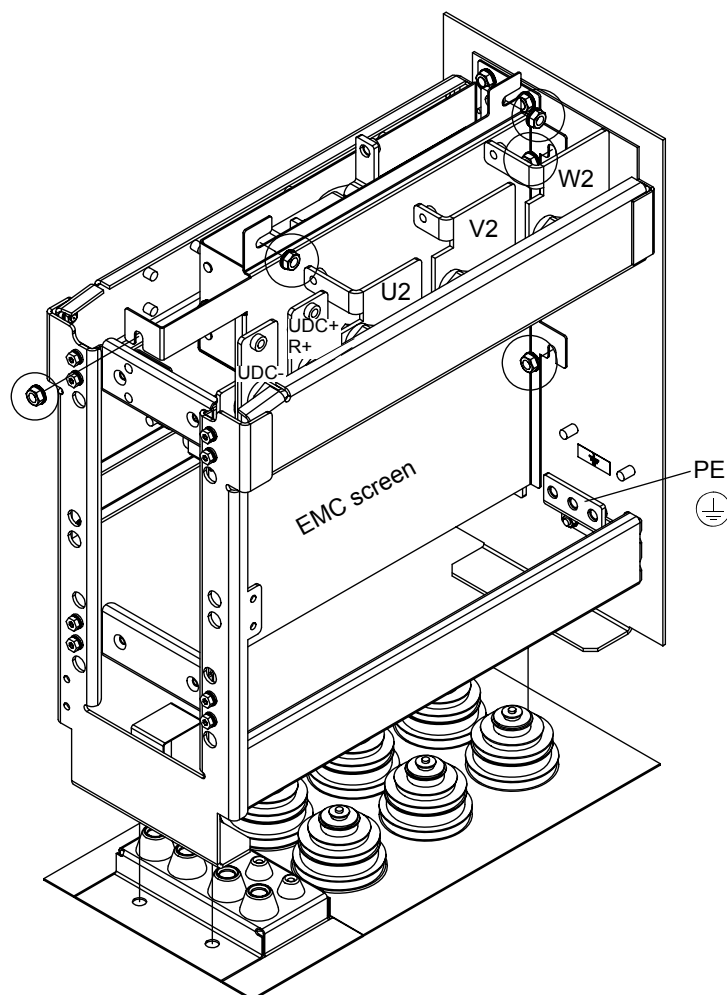
**Lead the power (input, motor and optional brake) cables through the lead-through plate:**

1. Make adequate holes in the grommets to fit them tightly on the cables.
2. Lead the cables through the holes and slide the grommets onto the cables.

- Prepare the power cables:**
1. Strip the cables.
 2. Twist the shield wires.
 3. Bend the conductors to the terminals.
 4. Cut the conductors to adequate length. Put the pedestal onto the lead-through plate and check the length of the conductors. Remove the pedestal.
 5. Crimp or screw cable lugs onto the conductors.
-  **WARNING!** The maximum allowed width of the cable lug is 38 mm (1.5 in.). Wider cable lugs may cause a short-circuit.
6. Connect the twisted shields of the cables to the PE busbar.
- Note:** 360 degrees grounding is not needed at the cable entry. The short twisted shield provides, in addition to the protective grounding, also sufficient disturbance suppression.

Frame size R7 without EMC screen

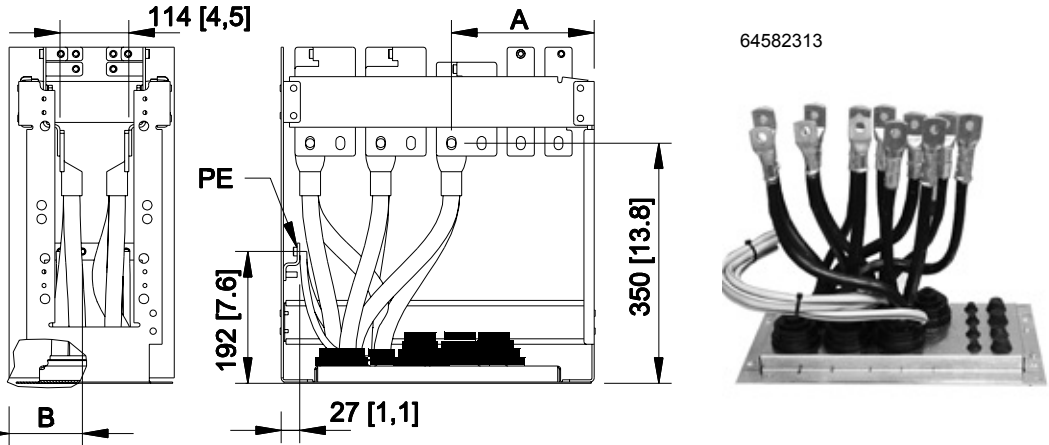

Terminal	U1, U2	V1, V2	W1, W2	UDC+/R+, R-	UDC-
A (hole 1) / mm [in.]	159 [6.3]	262 [10.3]	365 [14.4]	58 [2.3]	3 [0.1]
A (hole 2) / mm [in.]	115 [4.5]	218 [8.5]	321 [12.6]	-	-

PE busbar hole	1	2	3	4	5	6
B / mm [in.]	43 [1.7]	75 [3.0]	107 [4.2]	139 [5.5]	171 [6.7]	203 [8.0]

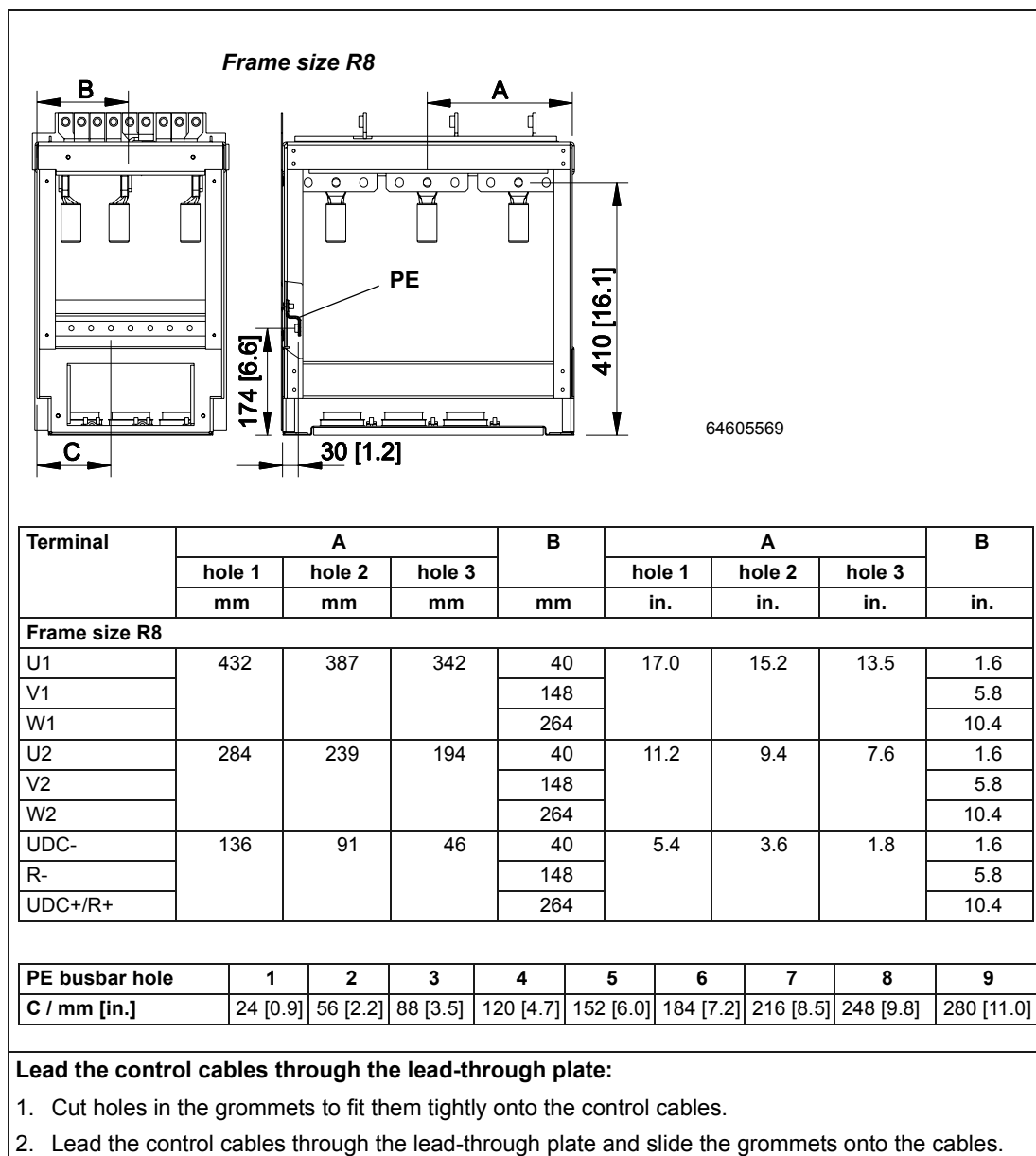

Connect the cable lugs to the pedestal:

1. If the lead-through plate is fixed to the floor, undo the fixing screws.
2. Place the pedestal onto the lead-through plate.
3. Fasten the pedestal and the lead-through plate to the floor with the screws through the same holes.
4. Connect the cable lugs to the pedestal (U1, V1, W1, U2, V2, W2 and PE; optional brake resistor cable lugs to UDC+/R+ and R-).
5. Tighten the connections.
6. Units with EMC screen (+E202): Fasten the EMC screen between the input and motor cables as shown on page 61.

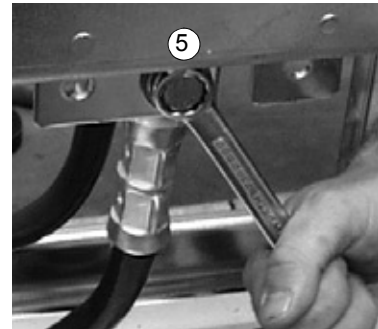
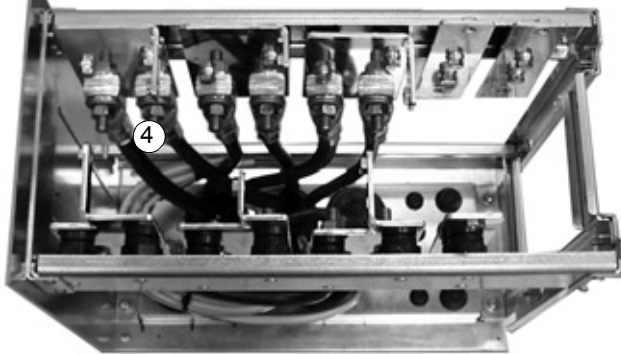
View of frame size R7 without EMC screen (+E202)

Frame sizes R7 and R8: M12 (1/2 in.) bolt
Tightening torque: 50...75 Nm (37...55 lbf ft)

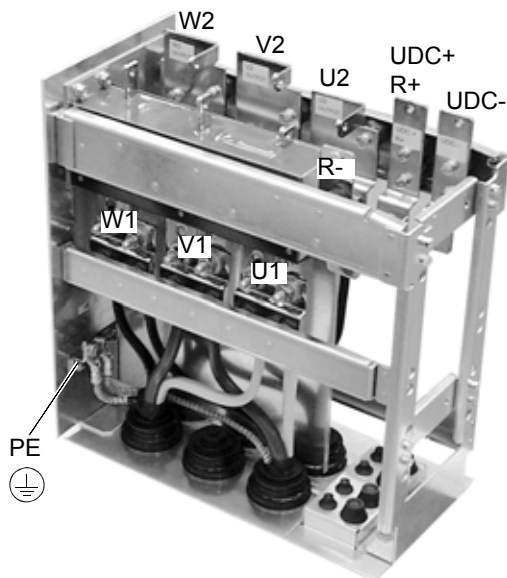
View of frame size R7 with EMC screen (+E202)

WARNING! It is not allowed to connect the cables directly to the drive module terminals. The leadthrough insulation material is not strong enough to carry the mechanical stress exerted by the cables. The cable connections must be performed in the pedestal.

Wheel the drive frame back on the pedestal (See step *Remove the pedestal*).

Fix the pedestal to the drive frame in reverse order to step *Remove the pedestal*:

1. Fix the fastening screws.



WARNING! The fixing is important because the screws are required for the grounding of the drive.

2. Connect the terminals at the top of the pedestal to the terminals at the bottom of the upper part of the drive frame.



WARNING! Be careful not to drop screws inside the pedestal. Loose metal pieces inside the unit may cause damage.

3. Tighten the connections.

View of frame size R7

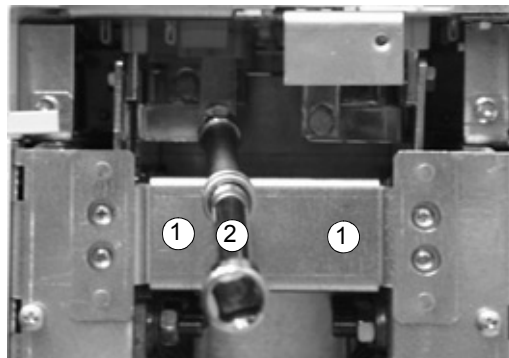

Terminal connection screws

R7: M8 combi screws

Tightening torque: 15...22 Nm (11...16 lbf ft)

R8: M10 combi screws

Tightening torque: 30...44 Nm (22...32 lbf ft)

Fasten the drive frame to the wall (recommended):

Fasten the unit with screws or bolts to the holes in the wall.

Note: In mounting orientation *a*, do not fasten the unit to wall if it is subjected to sideways vibration.

Connect the control cables as described in section [Connecting the control cables](#).

Fasten the covers

Mounting orientation *c* (lifting from above)

Make the installation otherwise as described in [Mounting orientations *a* and *b*](#) but leave the pedestal connected to the frame.

- Remove the lead-through plate and the lower front and side plates.
- Lift the drive frame onto the lead-through plate from above.
- Fasten the drive to the floor.
- Connect the cable lugs to the terminals.
- Fasten the lower front and side plates.
- Fasten the drive by top to the wall (recommended).

Note: When mounting the unit on wall, a support shelf is required, see the instructions in *ACS800-02/U2 Application Guide on Wall Mounting* [3AFE68250013 (English)].

Mounting orientation d (optional enclosure extension included)

The customer connections of the drive (power cable terminals, I/O terminal blocks, option module slots) are provided in the enclosure extension instead of the actual drive cubicle. The extension cubicle and the drive cubicle are fastened together at the factory with two screws at the top of the cubicles. The drive pedestal is fastened to the base plate of the enclosure extension.

Fastening the unit

See [Dimensional drawings](#) for the locations of the fastening points.

Fasten the unit to the floor with four screws using the holes provided in the base plate.

It is recommended to fasten the unit to the rear wall as well. Use the holes at the top of the enclosure extension and at the top of the drive cubicle. The enclosure extension is fastened as follows:

1. Remove the top lead-through plate.
2. Fasten the unit with screws or bolts to the holes in the wall.
3. Refasten the top lead-through plate.

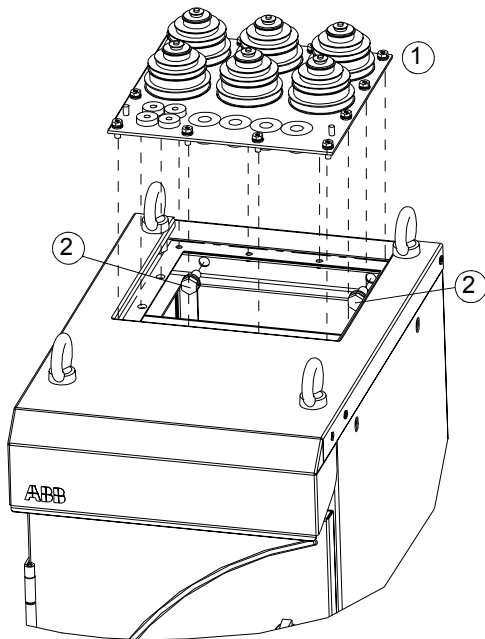

Connecting the power cables

Refer to [Dimensional drawings](#) for terminal locations and hole sizes. The same screw can be used for connecting two cable lugs (on both sides of the busbar).

Connecting the power cables of units without EMC filter +E202. Frame sizes R7 and R8.	
Step	Instruction
1	Lead the cables into the cubicle through the cable entries provided. Note: 360 degrees grounding is not needed at the cable entry. The short twisted shield provides, in addition to the protective grounding, also sufficient disturbance suppression.
2	Slide the grommets onto the cables.
3	Cut the cables to appropriate length.
4	Terminate the conductors with cable lugs or connectors.
5	Connect the cable shields to the PE busbar.
6	Connect the phase conductors of the motor cable to the U2, V2 and W2 terminals.
7	Connect the phase conductors of the supply cable to the U1, V1 and W1 terminals.
8	Connect the optional brake conductors to the R+ and R- terminals.

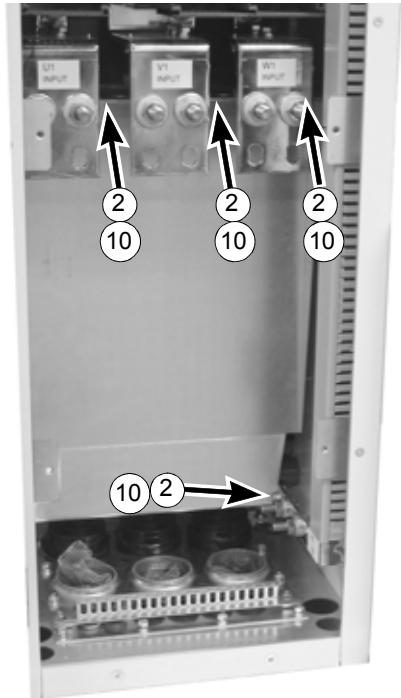
Connecting the power cables of units with EMC filter +E202. Frame size R7 with bottom entry and exit.		Photo
Step	Instruction	
1	Remove the shroud in front of the input terminals.	
2	Remove the EMC screen by undoing the fastenings screws: one at the right side, three behind the input terminals.	

Connecting the power cables of units with EMC filter +E202. Frame size R7 with bottom entry and exit.

Step	Instruction	Photo
3	Cut an adequate hole to the rubber grommet in the lead-through plate and lead the motor cable through the grommet and the conductive sleeve into the cabinet.	
4	Peel off 3 to 5 cm of the outer insulation of the cable above the lead-through plate for the 360° high-frequency earthing.	
5	Fasten the conductive sleeve to the cable shield with cable ties.	
6	Tie up the unused conductive sleeves with cable ties.	
7	Connect the twisted shield of the motor cable to the PE busbar of the cabinet.	
8	Connect the phase conductors of the motor cable to the U2, V2 and W2 terminals.	
9	If optional brake chopper is included, lead the brake resistor cable into the cubicle as described above. Connect the brake resistor conductors to the R+ and R- terminals and the twisted shield to the PE busbar.	
10	Fasten the EMC screen. See the photo on the previous page.	

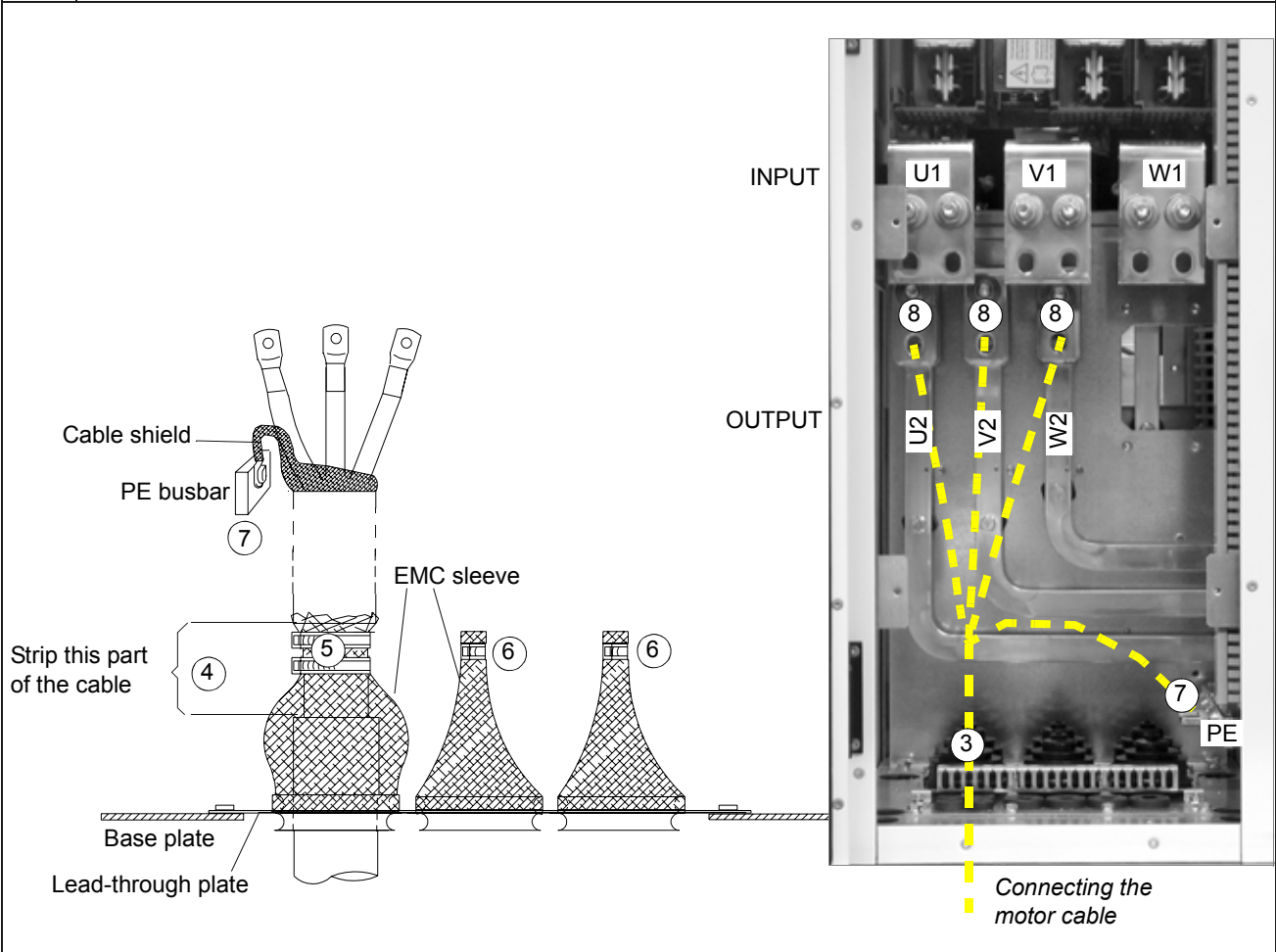

Connecting the power cables of units with EMC filter +E202. Frame size R7 with bottom entry and exit.		
Step	Instruction	Photo
11	It is recommended to make a 360 degrees grounding for the input cable in the same way as for the motor cable.	
12	Connect the twisted shield of the input cable to the PE busbar of the cabinet.	
13	Connect the phase conductors of the input cable to the U1, V1 and W1 terminals.	
14	Fasten the shroud.	

Connecting the power cables of units with EMC filter +E202. Frame size R7 with top entry and exit.		
Step	Instruction	Photo
1	Remove the shroud in front of the input terminals.	
2	Remove the EMC screen by undoing the fastening screws.	

Connecting the power cables of units with EMC filter +E202. Frame size R7 with top entry and exit.

Step	Instruction	Photo
3	Cut an adequate hole to the rubber grommet in the lead-through plate and lead the motor cable through the grommet and the conductive sleeve into the cabinet.	
4	Peel off 3 to 5 cm of the outer insulation of the cable below the lead-through plate for the 360° high-frequency earthing.	
5	Fasten the conductive sleeve to the cable shield with cable ties.	
6	Tie up the unused conductive sleeves with cable ties.	
7	Connect the twisted shield of the motor cable to the PE busbar of the cabinet.	
8	Connect the phase conductors of the motor cable to the U2, V2 and W2 terminals.	
9	If optional brake chopper is included, lead the brake resistor cable into the cubicle as described above. Connect the brake resistor conductors to the R+ and R- terminals and the twisted shield to the PE busbar.	
10	Fasten the EMC screen. See the photo on the previous page.	

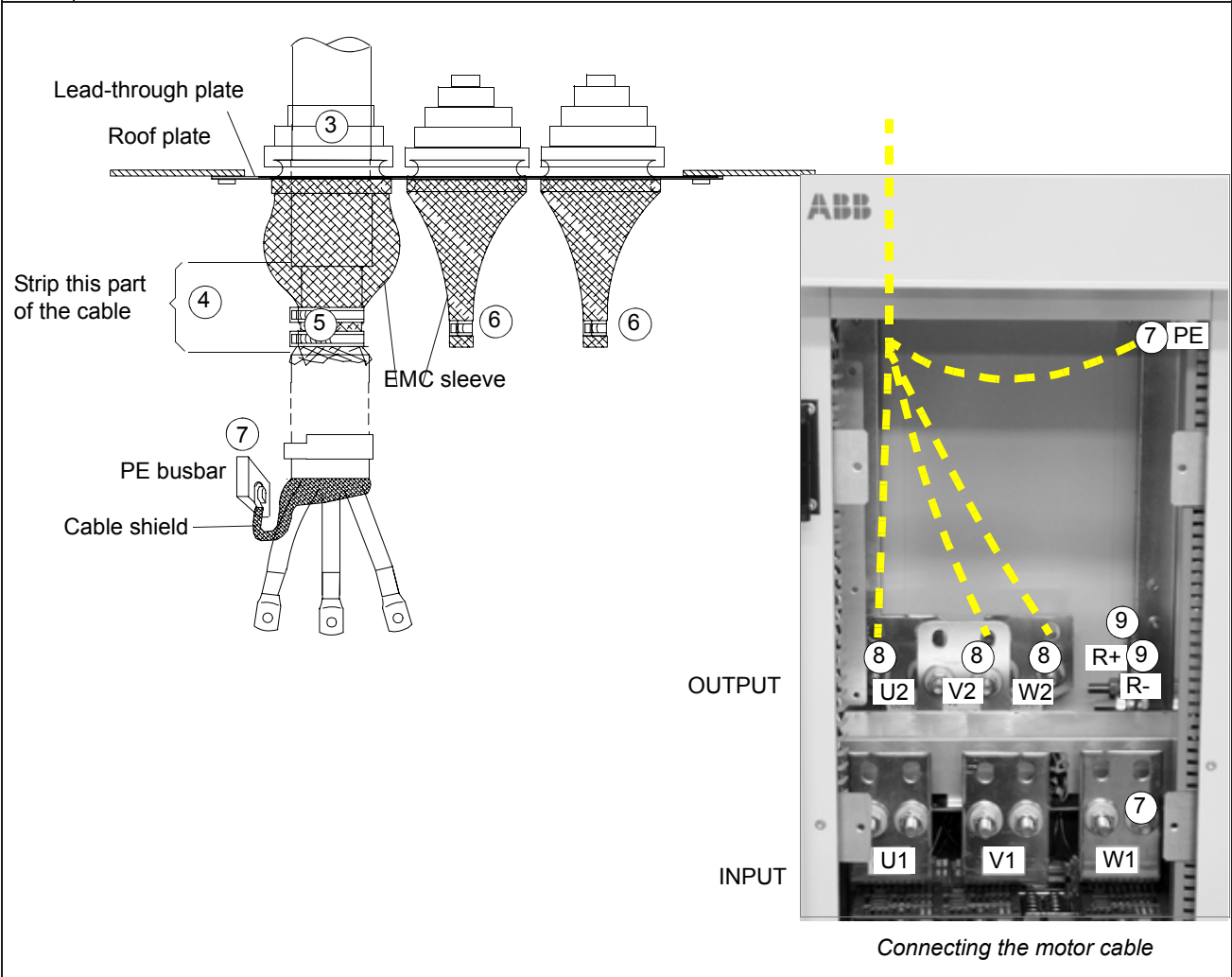

Connecting the power cables of units with EMC filter +E202. Frame size R7 with top entry and exit.		
Step	Instruction	Photo
11	It is recommended to make a 360 degrees grounding for the input cable in the same way as for the motor cable.	
12	Connect the twisted shield of the input cable to the PE busbar of the cabinet.	
13	Connect the phase conductors of the input cable to the U1, V1 and W1 terminals.	
14	Fasten the shroud.	

Connecting the power cables of units with EMC filter +E202. Frame size R8 with bottom entry and exit.		
Step	Instruction	Photo
1	Remove the shroud in front of the input terminals.	
2	Remove the EMC screen by undoing the 9 fastening screws and 1 fastening nut. Note: When refitting the screen, first fasten screws I II III, then the rest of the screws.	

Connecting the power cables of units with EMC filter +E202. Frame size R8 with bottom entry and exit.

Step	Instruction	Photo
3	Cut an adequate hole to the rubber grommet in the lead-through plate and lead the motor cable through the grommet and the conductive sleeve into the cabinet.	
4	Peel off 3 to 5 cm of the outer insulation of the cable above the lead-through plate for the 360° high-frequency earthing.	
5	Fasten the conductive sleeve to the cable shield with cable ties.	
6	Tie up the unused conductive sleeves with cable ties.	
7	Connect the twisted shield of the motor cable to the PE busbar of the cabinet.	
8	Connect the phase conductors of the motor cable to the U2, V2 and W2 terminals.	
9	If optional brake chopper is included, lead the brake resistor cable into the cubicle as described above. Connect the brake resistor conductors to the R+ and R- terminals and the twisted shield to the PE busbar.	
10	Fasten the EMC screen. See the photo on the previous page.	

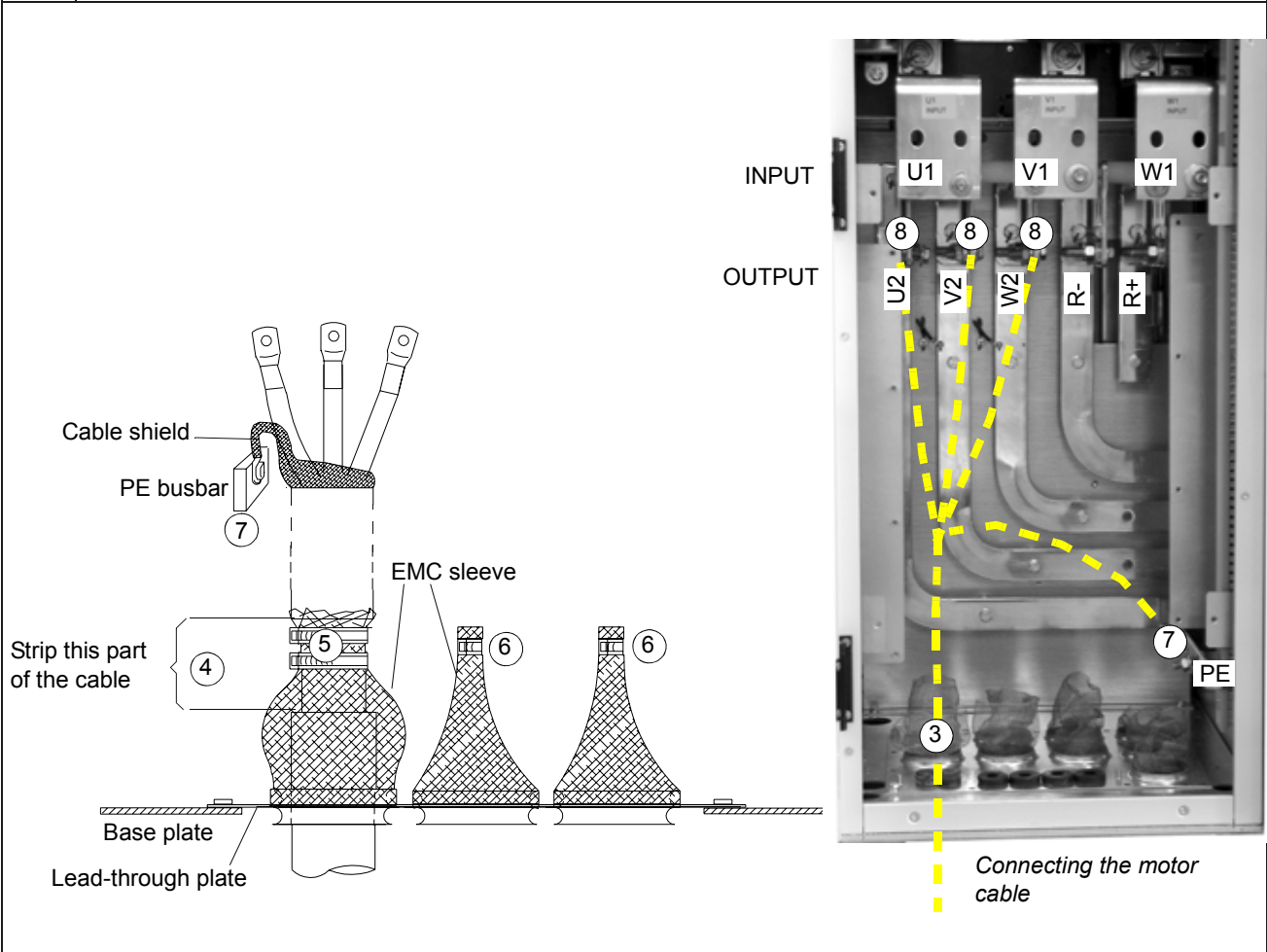

Connecting the power cables of units with EMC filter +E202. Frame size R8 with bottom entry and exit.		
Step	Instruction	Photo
11	It is recommended to make a 360 degrees grounding for the input cable in the same way as for the motor cable.	
12	Connect the twisted shield of the input cable to the PE busbar of the cabinet.	
13	Connect the phase conductors of the input cable to the U1, V1 and W1 terminals.	
14	Fasten the shroud.	

Connecting the power cables of units with EMC filter +E202. Frame size R8 with top entry and exit.		
Step	Instruction	Photo
1	Remove the shroud in front of the input terminals.	
2	Remove the EMC screens by undoing the fastening screws.	

Connecting the power cables of units with EMC filter +E202. Frame size R8 with top entry and exit.

Step	Instruction	Photo
3	Cut an adequate hole to the rubber grommet in the lead-through plate and lead the motor cable through the grommet and the conductive sleeve into the cabinet.	
4	Peel off 3 to 5 cm of the outer insulation of the cable above the lead-through plate for the 360° high-frequency earthing.	
5	Fasten the conductive sleeve to the cable shield with cable ties.	
6	Tie up the unused conductive sleeves with cable ties.	
7	Connect the twisted shield of the motor cable to the PE busbar of the cabinet.	
8	Connect the phase conductors of the motor cable to the U2, V2 and W2 terminals.	
9	If optional brake chopper is included, lead the brake resistor cable into the cubicle as described above. Connect the brake resistor conductors to the R+ and R- terminals and the twisted shield to the PE busbar.	
10	Fasten the EMC screens. See the photo on the previous page.	

Connecting the motor cable

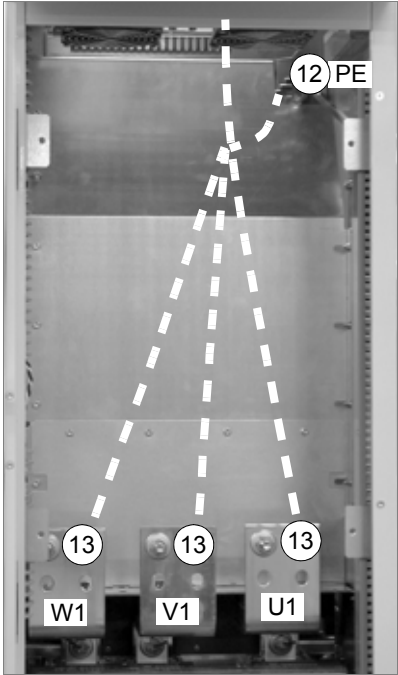
Connecting the power cables of units with EMC filter +E202. Frame size R8 with top entry and exit.		
Step	Instruction	Photo
11	It is recommended to make a 360 degrees grounding for the input cable in the same way as for the motor cable.	
12	Connect the twisted shield of the input cable to the PE busbar of the cabinet.	
13	Connect the phase conductors of the input cable to the U1, V1 and W1 terminals.	
	Fasten the shroud.	

Enclosure extension layout

There are two main layouts of the enclosure extension, one for each cabling direction. The pictures below show both the bottom and top entry/exit layouts of the enclosure extension.

Bottom cable entry/exit (R7)

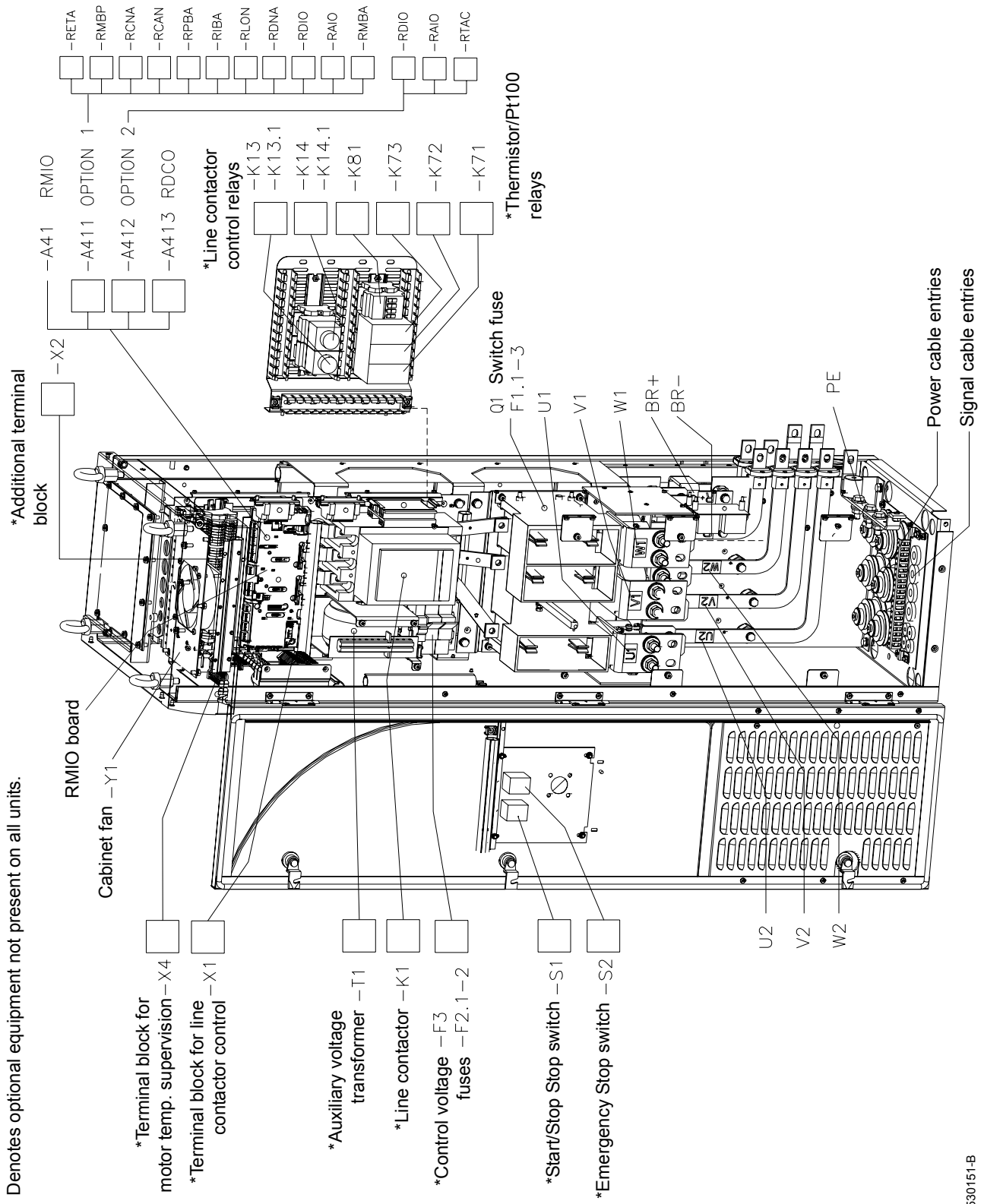

* Denotes optional equipment not present on all units.

64530151-B

Top cable entry/exit (R7)

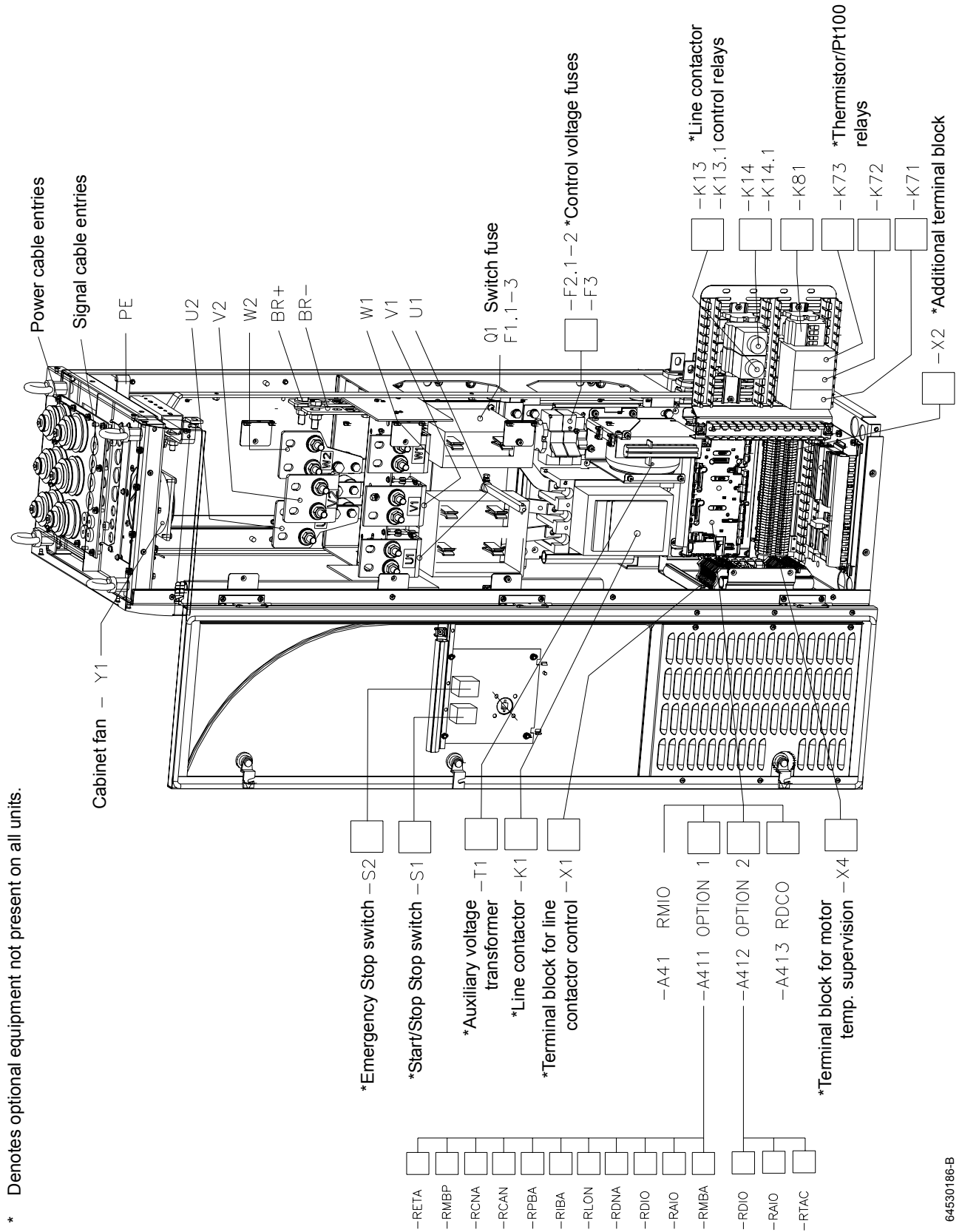

* Denotes optional equipment not present on all units.

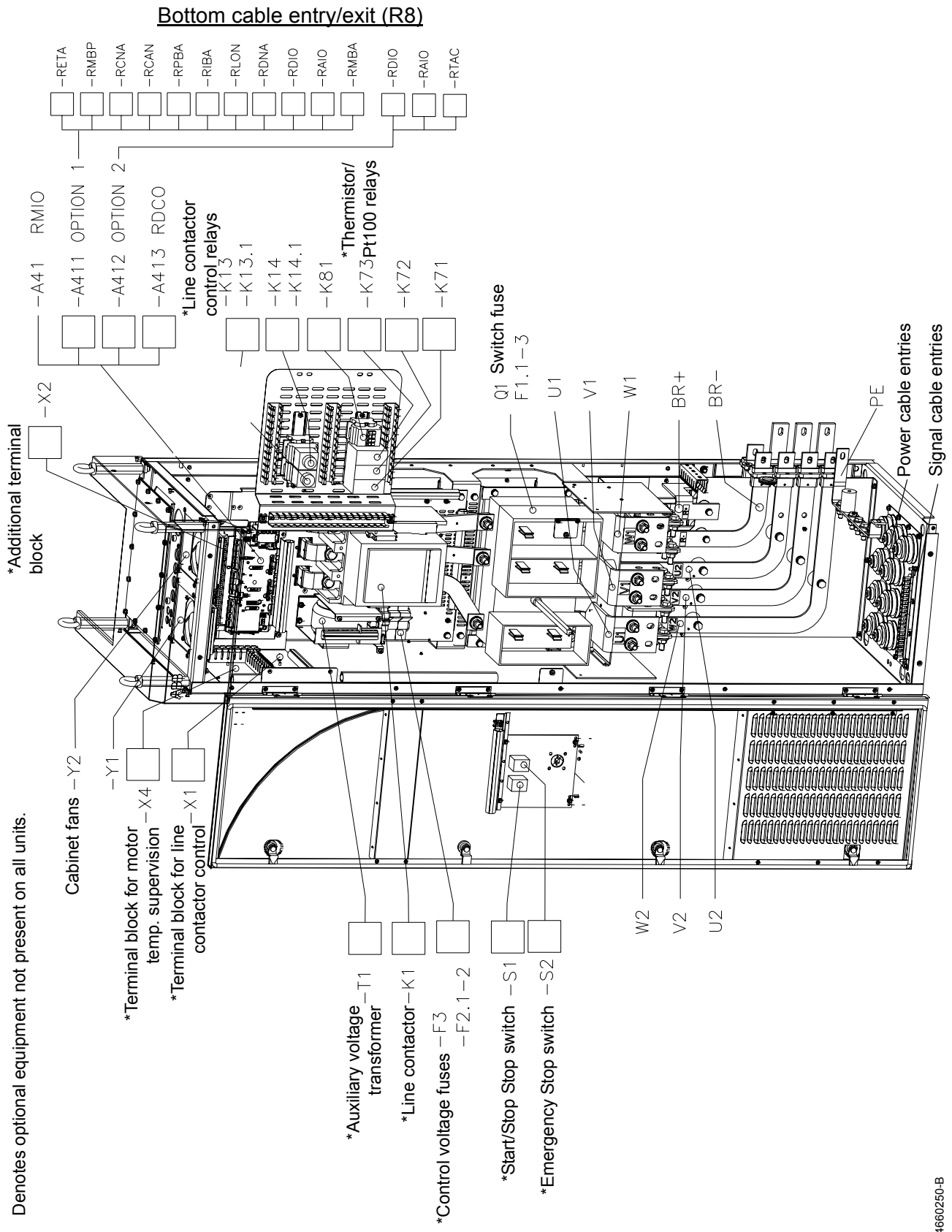

* Denotes optional equipment not present on all units.

*Terminal block for motor temp. supervision -X4
 *Terminal block for line contactor control -X1

*Auxiliary voltage transformer -T1
 *Line contactor -K1
 *Control voltage fuses -F3
 -F2.1-2
 *Start/Stop switch -S1
 *Emergency Stop switch -S2

Bottom cable entry/exit (R8)

-A41 RMIO
 -A411 OPTION 1
 -A412 OPTION 2
 -A413 RDCO
 *Line contactor control relays
 -K13
 -K13.1
 -K14
 -K14.1
 -K81
 *Thermistor/Pt100 relays
 -K72
 -K71
 -RETA
 -RMBP
 -RCNA
 -RCAN
 -RPBA
 -RIBA
 -RLON
 -RDNA
 -RDIO
 -RAIO
 -RMA
 -RDIO
 -RAIO
 -RTAC

Top cable entry/exit (R8)

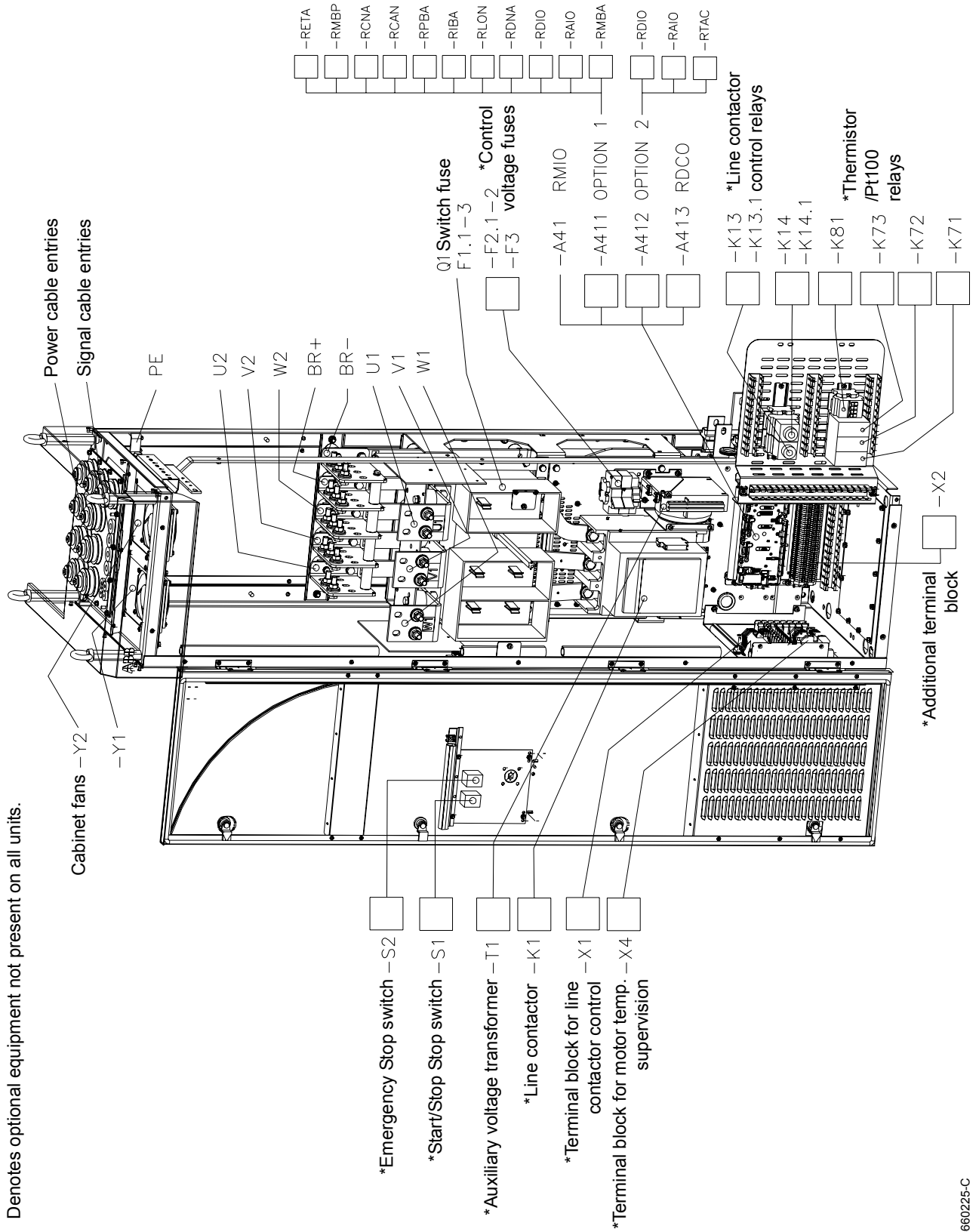

* Denotes optional equipment not present on all units.

- *Emergency Stop switch -S2
- *Start/Stop Stop switch -S1
- *Auxiliary voltage transformer -T1
- *Line contactor -K1
- *Terminal block for line contactor control -X1
- *Terminal block for motor temp. supervision -X4

Main wiring diagram

The diagram below presents the main wiring of the enclosure extension. Note that the diagram includes optional components (marked *) which are not always included in the delivery.

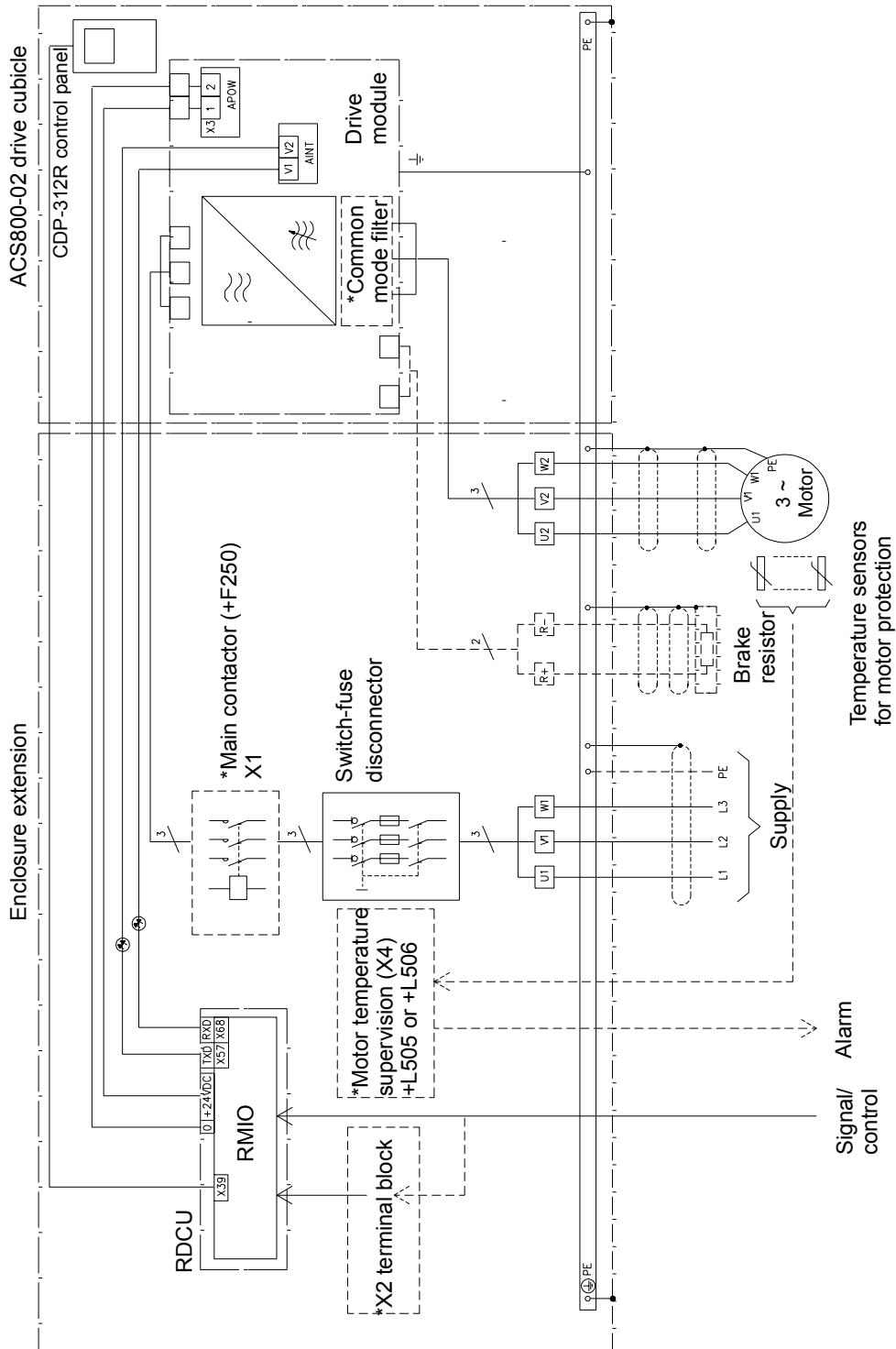

Routing the control/signal cables inside the cubicle

Units without an enclosure extension

Frame size R7

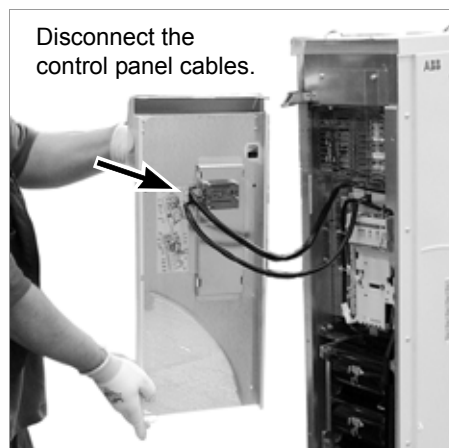
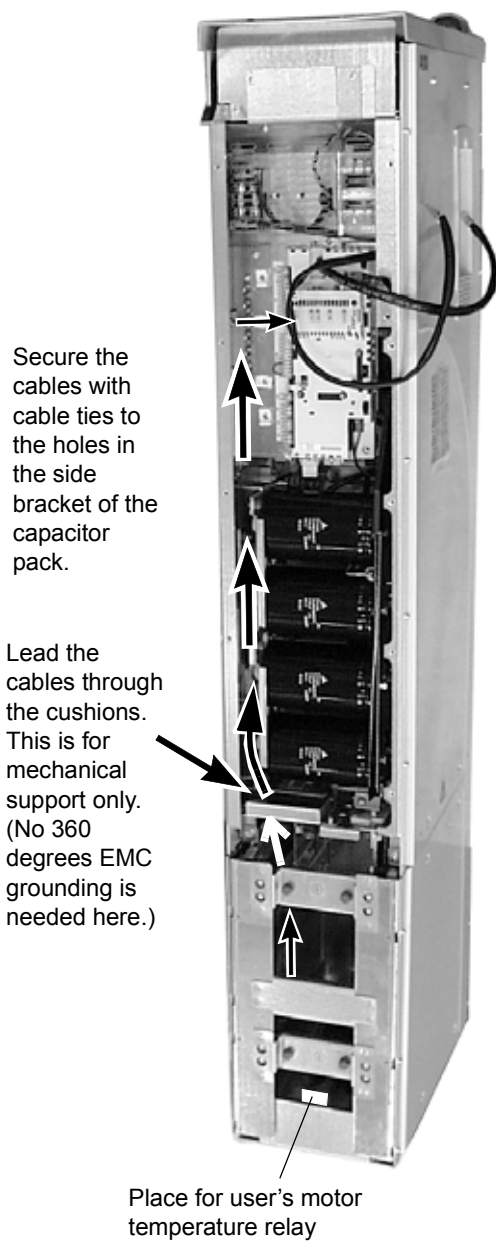

Opening the top front cover (R7)

Frame size R8

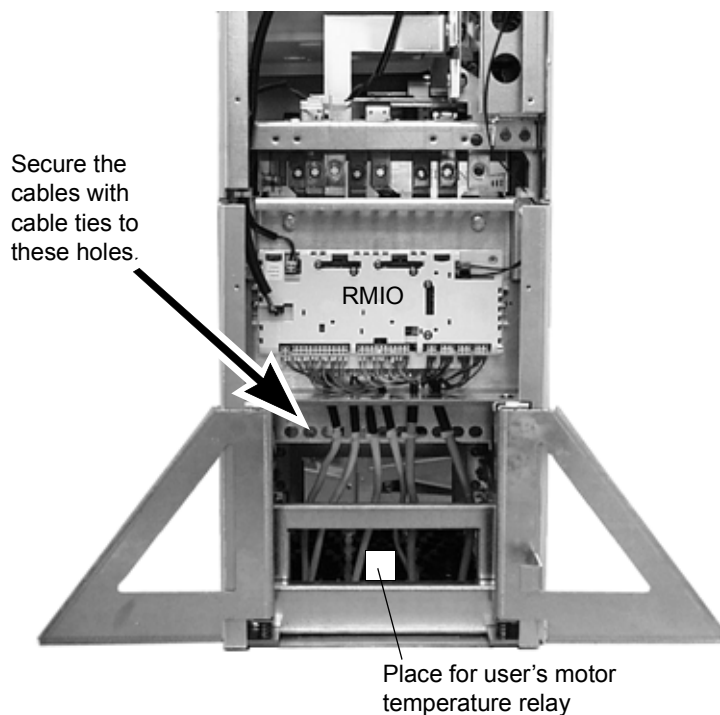

Units with enclosure extension

Cable entries with grommets for multiple cable diameters are provided.

The following diagram gives an example of signal/control cabling routing inside the cubicle.

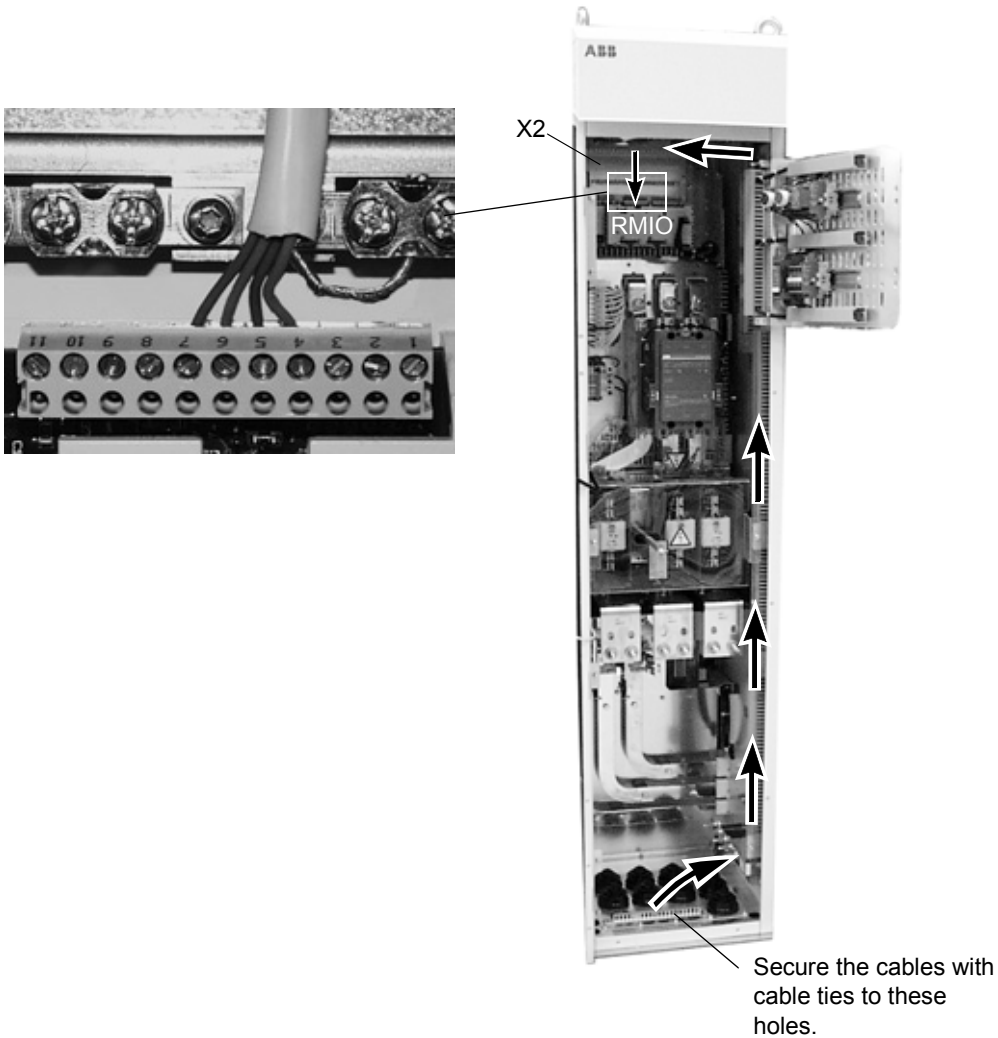

Connecting the control cables

Connect the control cables as described below. Connect the conductors to the appropriate detachable terminals of the RMIO board (refer to chapter [Motor control and I/O board \(RMIO\)](#)). Tighten the screws to secure the connection.

Connecting the shield wires at RMIO board

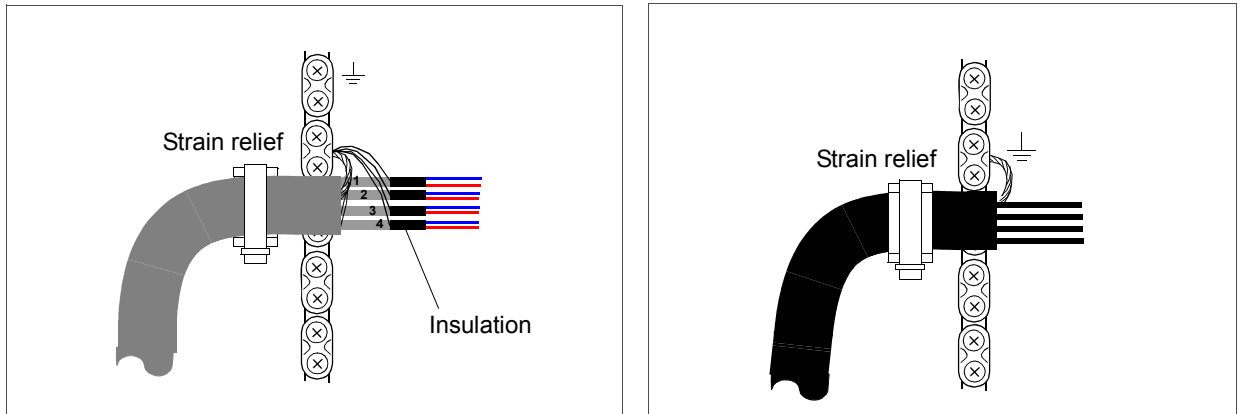

Double-shielded cable

Single-shielded cable

Single-shielded cable: Twist the grounding wires of the outer shield and connect them to the nearest grounding clamp. **Double-shielded cable:** Connect the inner shields and the grounding wires of the outer shield to the nearest grounding clamp.

Do not connect shields of different cables to the same grounding clamp.

Leave the other end of the shield unconnected or ground it indirectly via a few nanofarads high-frequency capacitor (e.g. 3.3 nF / 630 V). The shield can also be grounded directly at both ends if they are *in the same ground line* with no significant voltage drop between the end points.

Keep the signal wire pairs twisted as close to the terminals as possible. Twisting the wire with its return wire reduces disturbances caused by inductive coupling.

Securing the control cables mechanically

Use strain relief clamps as shown above. Fasten the control cables together and to the drive frame with cable ties as shown in section [Routing the control/signal cables inside the cubicle](#).

Settings of the cooling fan transformer

The voltage transformer of the cooling fan (T41) is located at the top of the drive module.

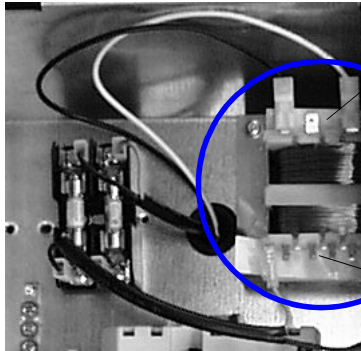

Set to 220 V if the supply frequency is 60 Hz. (The voltage is set to 230 V (50 Hz) at the factory.)

Set according to the supply voltage:
380 V, 400 V, 415 V, 440 V, 480 V or 500 V; or
525 V, 575 V, 600 V, 660 V or 690 V.

Note: No need to set for 230 V units.

Setting of the auxiliary voltage transformer of the line contactor option

Adjust the setting of the transformer (T1, located in the enclosure extension) according to the input voltage.

Installation of optional modules and PC

The optional module (such as fieldbus adapter, I/O extension module and the pulse encoder interface) is inserted in the optional module slot of the RMIO board and fixed with two screws. See the appropriate optional module manual for cable connections.

Cabling of I/O and fieldbus modules

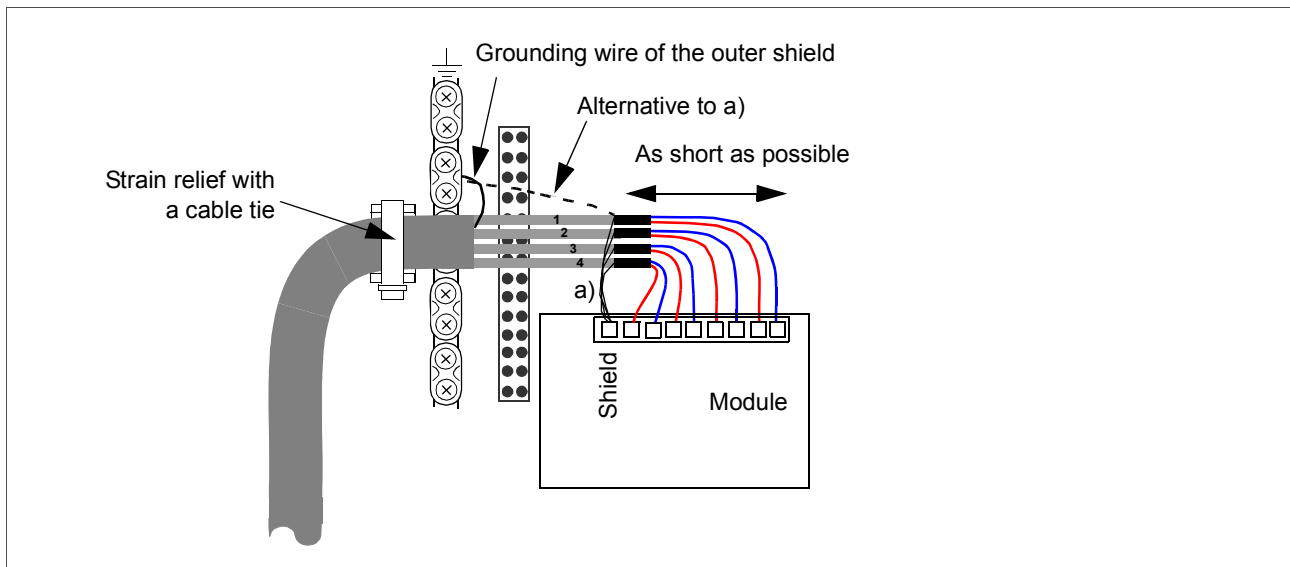

Pulse encoder module cabling

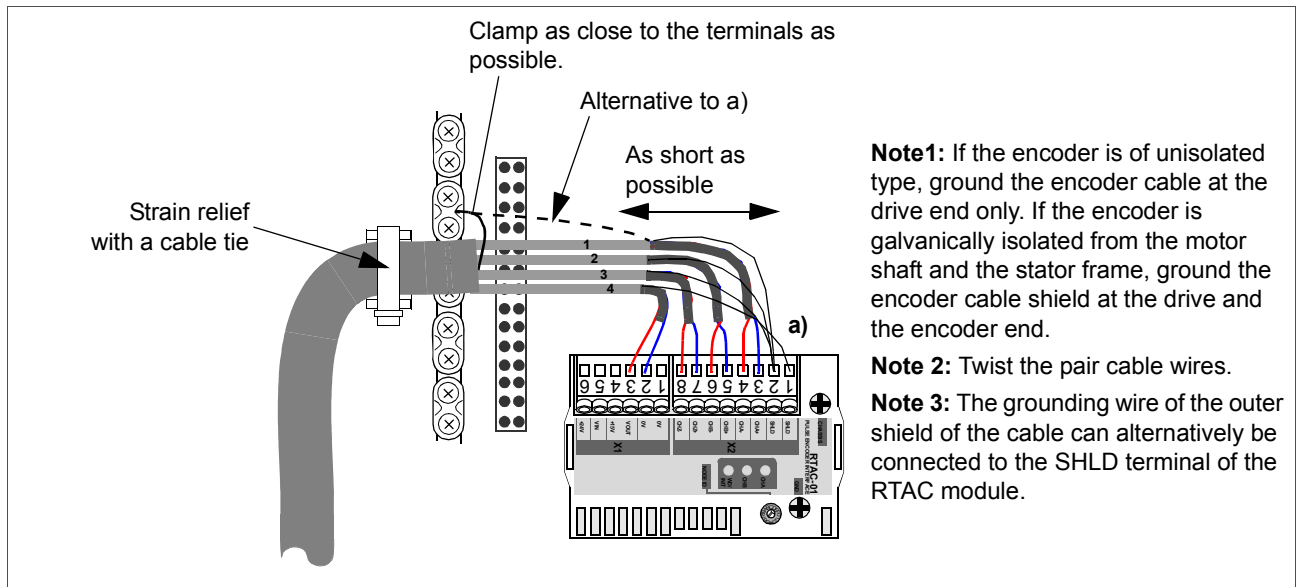

Fibre optic link

A DDCS fibre optic link is provided via the RDCO optional module for PC tools, master/follower link, NDIO, NTAC, NAI0, AIMA I/O module adapter and fieldbus adapter modules of type Nxxx. See *RDCO User's Manual* [3AFE64492209 (English)] for the connections. Observe colour coding when installing fibre optic cables. Blue connectors go to blue terminals and grey connectors to grey terminals.

When installing multiple modules on the same channel, connect them in a ring.

Installation of user's own relays

A motor thermistor relay can be installed to a rail in the pedestal (frame size R7) or on the lead-through plate (frame size R8), or to a DIN rail in the enclosure extension.

Installation of brake resistors

See [Resistor braking](#). Connect the resistor as shown in section [Power cable connection diagram](#) above.

Parameter settings

To enable dynamic braking, certain drive parameters must be adjusted. For further information, refer to the *Firmware Manual*.

Fill-in user connections diagram

The following diagram is a fill-in template for the user's power and control cable connections of units without enclosure extension. Factory Macro configurations of ACS800 Standard Control Program are shown. For other programs and macros, refer to the appropriate firmware manual.

By completing the diagram you can document your installation for future use/reference.

Wiring diagram template

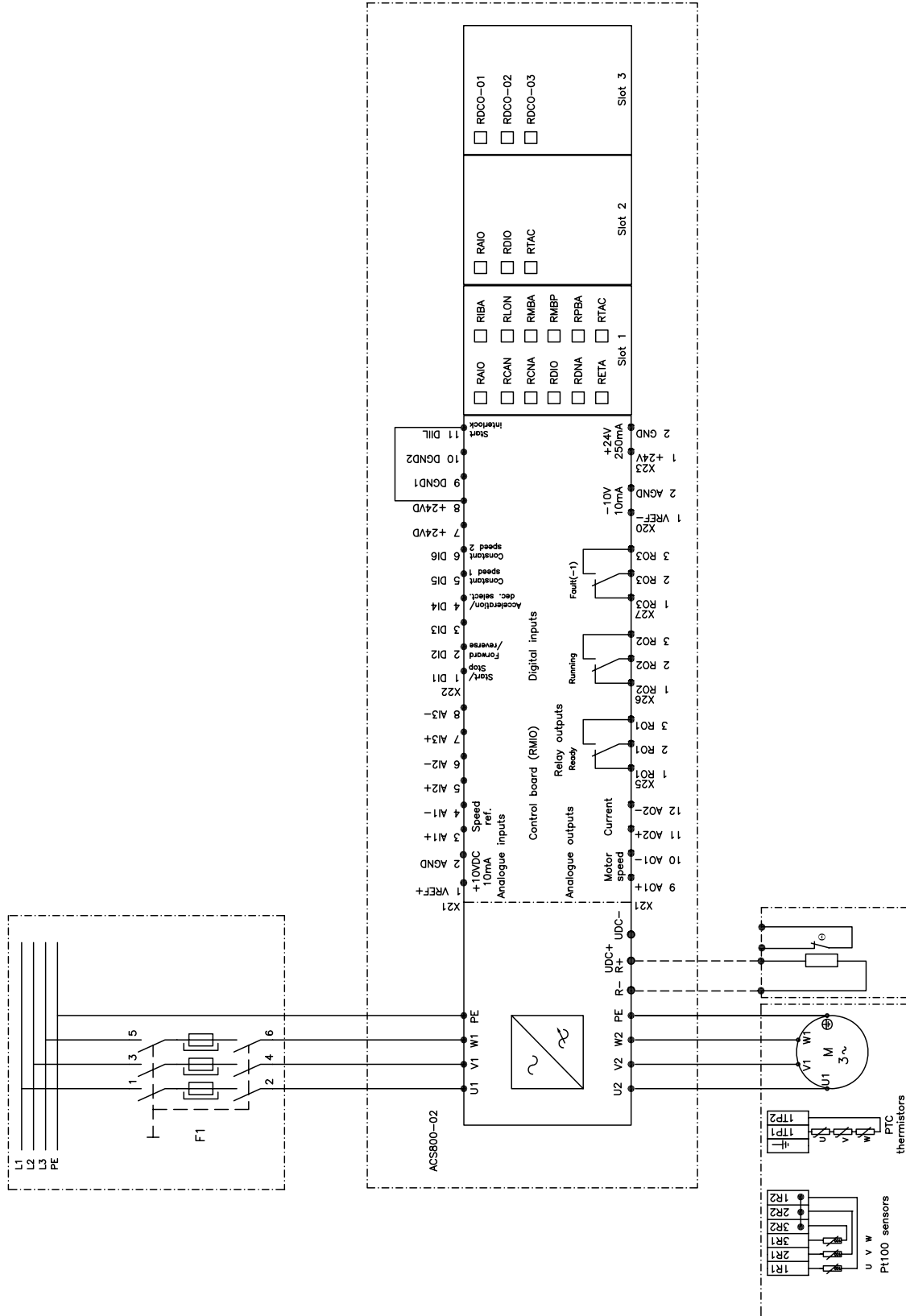

Motor control and I/O board (RMIO)

What this chapter contains

This chapter shows

- external control connections to the RMIO board for the ACS800 Standard Control Program (Factory Macro)
- specifications of the inputs and outputs of the board.

To which products this chapter applies

This chapter applies to ACS800 units which employ RMIO-01 board from revision J onwards and RMIO-02 board from revision H onwards.

Note for the ACS800-02 with enclosure extension and the ACS800-07

The connections for the RMIO board shown below apply also to optional terminal block X2 available for the ACS800-02 and ACS800-07. The terminals of the RMIO board are wired to terminal block X2 internally.

Terminals of X2 accept cables from 0.5 to 4.0 mm² (22 to 12 AWG). Tightening torque for screw terminals is 0.4 to 0.8 Nm (0.3 to 0.6 lbf ft). For disconnecting wires from spring terminals, use a screw driver with a blade thickness of 0.6 mm (0.024 in.) and width of 3.5 mm (0.138 in.), e.g. PHOENIX CONTACT SZF 1-0,6X3,5.

Note on terminal labelling

Optional modules (Rxxx) may have identical terminal designations with the RMIO board.

Note on external power supply

External +24 V power supply for the RMIO board is recommended if

- the application requires a fast start after connecting the input power supply
- fieldbus communication is required when the input power supply is disconnected.

The RMIO board can be supplied from an external power source via terminal X23 or X34 or via both X23 and X34. The internal power supply to terminal X34 can be left connected when using terminal X23.



WARNING! If the RMIO board is supplied from an external power source via terminal X34, the loose end of the cable removed from the RMIO board terminal must be secured mechanically to a location where it cannot come into contact with electrical parts. If the screw terminal plug of the cable is removed, the wire ends must be individually insulated.

Parameter settings

In Standard Control Program, set parameter 16.9 CTRL BOARD SUPPLY to EXTERNAL 24V if the RMIO board is powered from an external supply.

External control connections (non-US)

External control cable connections to the RMIO board for the ACS800 Standard Control Program (Factory Macro) are shown below. For external control connections of other control macros and programs, see the appropriate *Firmware Manual*.

RMIO

Terminal block size:

cables 0.3 to 3.3 mm² (22 to 12 AWG)

Tightening torque:

0.2 to 0.4 Nm

(0.2 to 0.3 lbf ft)

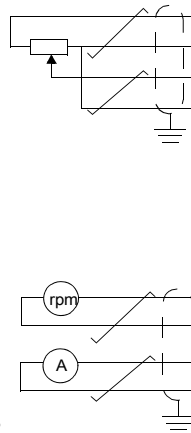

* optional terminal block in ACS800-02 and ACS800-07

1) Only effective if par. 10.03 is set to REQUEST by the user.

2) 0 = open, 1 = closed

DI4	Ramp times according to
0	parameters 22.02 and 22.03
1	parameters 22.04 and 22.05

3) See par. group 12 CONSTANT SPEEDS.

DI5	DI6	Operation
0	0	Set speed through AI1
1	0	Constant speed 1
0	1	Constant speed 2
1	1	Constant speed 3

4) See parameter 21.09 START INTRL FUNC.

5) Total maximum current shared between this output and optional modules installed on the board.

X2*	RMIO		
X20	X20	1	VREF-
		2	AGND
X21	X21	1	VREF+
		2	AGND
		3	AI1+
		4	AI1-
		5	AI2+
		6	AI2-
		7	AI3+
		8	AI3-
		9	AO1+
		10	AO1-
		11	AO2+
		12	AO2-
X22	X22	1	DI1
		2	DI2
		3	DI3
		4	DI4
		5	DI5
		6	DI6
		7	+24VD
		8	+24VD
		9	DGND1
		10	DGND2
		11	DIIL
X23	X23	1	+24V
		2	GND
X25	X25	1	RO1
		2	RO1
		3	RO1
X26	X26	1	RO2
		2	RO2
		3	RO2
X27	X27	1	RO3
		2	RO3
		3	RO3

External control connections (US)

External control cable connections to the RMIO board for the ACS800 Standard Control Program (Factory Macro US version) are shown below. For external control connections of other control macros and programs, see the appropriate *Firmware Manual*.

RMIO

Terminal block size:

cables 0.3 to 3.3 mm² (22 to 12 AWG)

Tightening torque:

0.2 to 0.4 Nm (0.2 to 0.3 lbf ft)

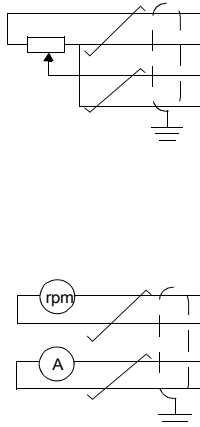

X2*	RMIO		
X20	X20	1	VREF-
		2	AGND
X21	X21	1	VREF+
		2	AGND
		3	AI1+
		4	AI1-
		5	AI2+
		6	AI2-
		7	AI3+
		8	AI3-
		9	AO1+
		10	AO1-
		11	AO2+
		12	AO2-
X22	X22	1	DI1
		2	DI2
		3	DI3
		4	DI4
		5	DI5
		6	DI6
		7	+24VD
		8	+24VD
		9	DGND1
		10	DGND2
		11	DIIL
X23	X23	1	+24V
		2	GND
X25	X25	1	RO1
		2	RO1
		3	RO1
X26	X26	1	RO2
		2	RO2
		3	RO2
X27	X27	1	RO3
		2	RO3
		3	RO3

* optional terminal block in ACS800-U2 and ACS800-U7

1) Only effective if par. 10.03 is set to REQUEST by the user.

2) 0 = open, 1 = closed

DI4	Ramp times according to
0	parameters 22.02 and 22.03
1	parameters 22.04 and 22.05

3) See par. group 12 CONSTANT SPEEDS.

DI5	DI6	Operation
0	0	Set speed through AI1
1	0	Constant speed 1
0	1	Constant speed 2
1	1	Constant speed 3

4) See parameter 21.09 START INTRL FUNC.

5) Total maximum current shared between this output and optional modules installed on the board.

RMIO board specifications

Analogue inputs

	With Standard Control Program two programmable differential current inputs (0 mA / 4 mA ... 20 mA, $R_{in} = 100 \text{ ohm}$) and one programmable differential voltage input (-10 V / 0 V / 2 V ... +10 V, $R_{in} = 200 \text{ kohm}$).
	The analogue inputs are galvanically isolated as a group.
Insulation test voltage	500 VAC, 1 min
Max. common mode voltage between the channels	$\pm 15 \text{ VDC}$
Common mode rejection ratio	$\geq 60 \text{ dB}$ at 50 Hz
Resolution	0.025% (12 bit) for the -10 V ... +10 V input. 0.5% (11 bit) for the 0 ... +10 V and 0 ... 20 mA inputs.
Inaccuracy	$\pm 0.5\%$ (Full Scale Range) at 25 °C (77 °F). Temperature coefficient: $\pm 100 \text{ ppm}/^{\circ}\text{C}$ ($\pm 56 \text{ ppm}/^{\circ}\text{F}$), max.

Constant voltage output

Voltage	+10 VDC, 0, -10 VDC $\pm 0.5\%$ (Full Scale Range) at 25 °C (77 °F). Temperature coefficient: $\pm 100 \text{ ppm}/^{\circ}\text{C}$ ($\pm 56 \text{ ppm}/^{\circ}\text{F}$) max.
Maximum load	10 mA
Applicable potentiometer	1 kohm to 10 kohm

Auxiliary power output

Voltage	24 VDC $\pm 10\%$, short circuit proof
Maximum current	250 mA (shared between this output and optional modules installed on the RMIO)

Analogue outputs

	Two programmable current outputs: 0 (4) to 20 mA, $R_L \leq 700 \text{ ohm}$
Resolution	0.1% (10 bit)
Inaccuracy	$\pm 1\%$ (Full Scale Range) at 25 °C (77 °F). Temperature coefficient: $\pm 200 \text{ ppm}/^{\circ}\text{C}$ ($\pm 111 \text{ ppm}/^{\circ}\text{F}$) max.

Digital inputs

	With Standard Control Program six programmable digital inputs (common ground: 24 VDC, -15% to +20%) and a start interlock input. Group isolated, can be divided in two isolated groups (see Isolation and grounding diagram below).
	Thermistor input: 5 mA, $< 1.5 \text{ kohm} \hat{=} \text{"1"}$ (normal temperature), $> 4 \text{ kohm} \hat{=} \text{"0"}$ (high temperature), open circuit $\hat{=} \text{"0"}$ (high temperature).
	Internal supply for digital inputs (+24 VDC): short-circuit proof. An external 24 VDC supply can be used instead of the internal supply.
Insulation test voltage	500 VAC, 1 min
Logical thresholds	$< 8 \text{ VDC} \hat{=} \text{"0"}$, $> 12 \text{ VDC} \hat{=} \text{"1"}$
Input current	DI1 to DI 5: 10 mA, DI6: 5 mA
Filtering time constant	1 ms

Relay outputs

	Three programmable relay outputs
Switching capacity	8 A at 24 VDC or 250 VAC, 0.4 A at 120 VDC
Minimum continuous current	5 mA rms at 24 VDC
Maximum continuous current	2 A rms
Insulation test voltage	4 kVAC, 1 minute

DDCS fibre optic link

With optional communication adapter module RDCO. Protocol: DDCS (ABB Distributed Drives Communication System)

24 VDC power input

Voltage	24 VDC \pm 10%
Typical current consumption (without optional modules)	250 mA
Maximum current consumption	1200 mA (with optional modules inserted)

The terminals on the RMIO board as well as on the optional modules attachable to the board fulfil the Protective Extra Low Voltage (PELV) requirements stated in EN 50178 provided that the external circuits connected to the terminals also fulfil the requirements and the installation site is below 2000 m (6562 ft). Above 2000 m (6562 ft), see page [48](#).

Isolation and grounding diagram

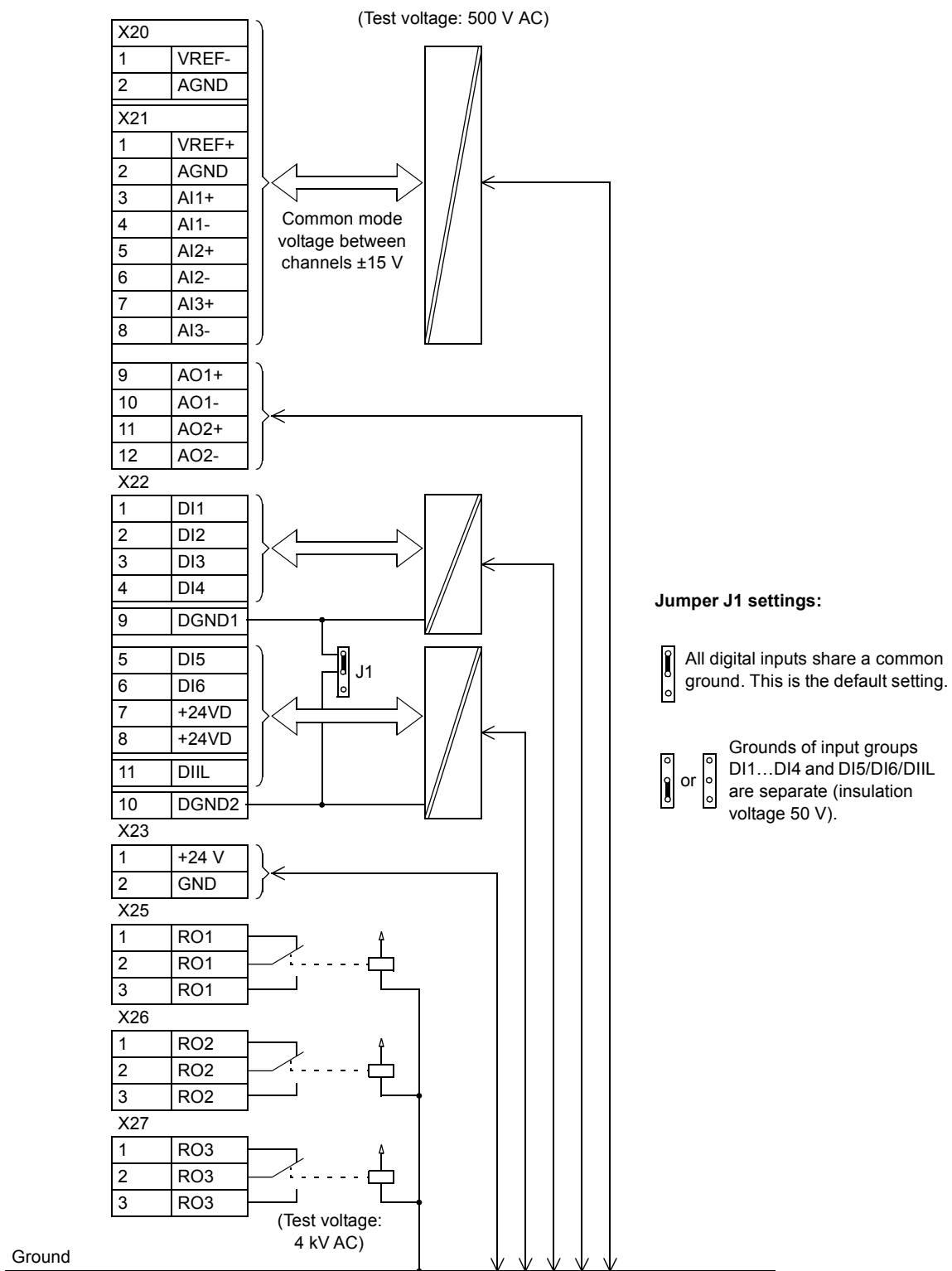

Installation checklist

Checklist

Check the mechanical and electrical installation of the drive before start-up. Go through the checklist below together with another person. Read the [Safety instructions](#) on the first pages of this manual before you work on the unit.

Check	
MECHANICAL INSTALLATION	
The ambient operating conditions are allowed. See Installation, Technical data: IEC data or NEMA data, Ambient conditions .	<input type="checkbox"/>
The unit is fixed properly on floor and a vertical non-flammable wall. See Installation .	<input type="checkbox"/>
The cooling air will flow freely.	<input type="checkbox"/>
ELECTRICAL INSTALLATION See Planning the electrical installation, Installation .	
The motor and the driven equipment are ready for start. See Planning the electrical installation: Motor selection and compatibility, Technical data: Motor connection .	<input type="checkbox"/>
The +E202 EMC filter capacitors are disconnected if the drive is connected to an IT (ungrounded) system.	<input type="checkbox"/>
The capacitors are reformed if stored over one year (refer to ACS 600/800 Capacitor Reforming Guide [3AFE64059629 (English)]).	<input type="checkbox"/>
The drive is grounded properly.	<input type="checkbox"/>
The mains (input power) voltage matches the drive nominal input voltage.	<input type="checkbox"/>
The mains (input power) connections at U1, V1 and W1 and their tightening torques are OK.	<input type="checkbox"/>
Appropriate mains (input power) fuses and disconnectors are installed.	<input type="checkbox"/>
The motor connections at U2, V2 and W2 and their tightening torques are OK.	<input type="checkbox"/>
The motor cable is routed away from other cables.	<input type="checkbox"/>
Setting of the fan voltage transformer	<input type="checkbox"/>
Setting of the auxiliary voltage transformer (option +G304)	<input type="checkbox"/>
There are no power factor compensation capacitors in the motor cable.	<input type="checkbox"/>
The external control connections inside the drive are OK.	<input type="checkbox"/>
There are no tools, foreign objects or dust from drilling inside the drive.	<input type="checkbox"/>
Mains (input power) voltage cannot be applied to the output of the drive (with bypass connection).	<input type="checkbox"/>
Drive, motor connection box and other covers are in place.	<input type="checkbox"/>

Maintenance

What this chapter contains

This chapter contains preventive maintenance instructions.

Safety



WARNING! Read the [Safety instructions](#) on the first pages of this manual before performing any maintenance on the equipment. Ignoring the safety instructions can cause injury or death. **Note:** There are parts carrying dangerous voltages near the RMIO board when the drive is powered.

Maintenance intervals

If installed in an appropriate environment, the drive requires very little maintenance. This table lists the routine maintenance intervals recommended by ABB.

Interval	Maintenance	Instruction
Every year when stored	Capacitor reforming	See Reforming .
Every 6 to 12 months (depending on the dustiness of the environment)	Heatsink temperature check and cleaning	See Heatsink .
Every 3 years	Enclosure extension cooling fan	See Fan .
Every 6 years	Cooling fan change	See Fan .
Every 10 years	Capacitor change	See Capacitors .
Every 5 years	Enclosure extension cooling fan change (with contactor option)	See Replacing the fan(s) of the enclosure extension

Layout

The layout stickers of the drive are shown below. The stickers show all possible components. Not all of them are present in each delivery or described here.

Designation	Component
A49	Control panel
A41	Motor control and I/O board (RMIO)
Y41	Cooling fan
C_	Capacitors

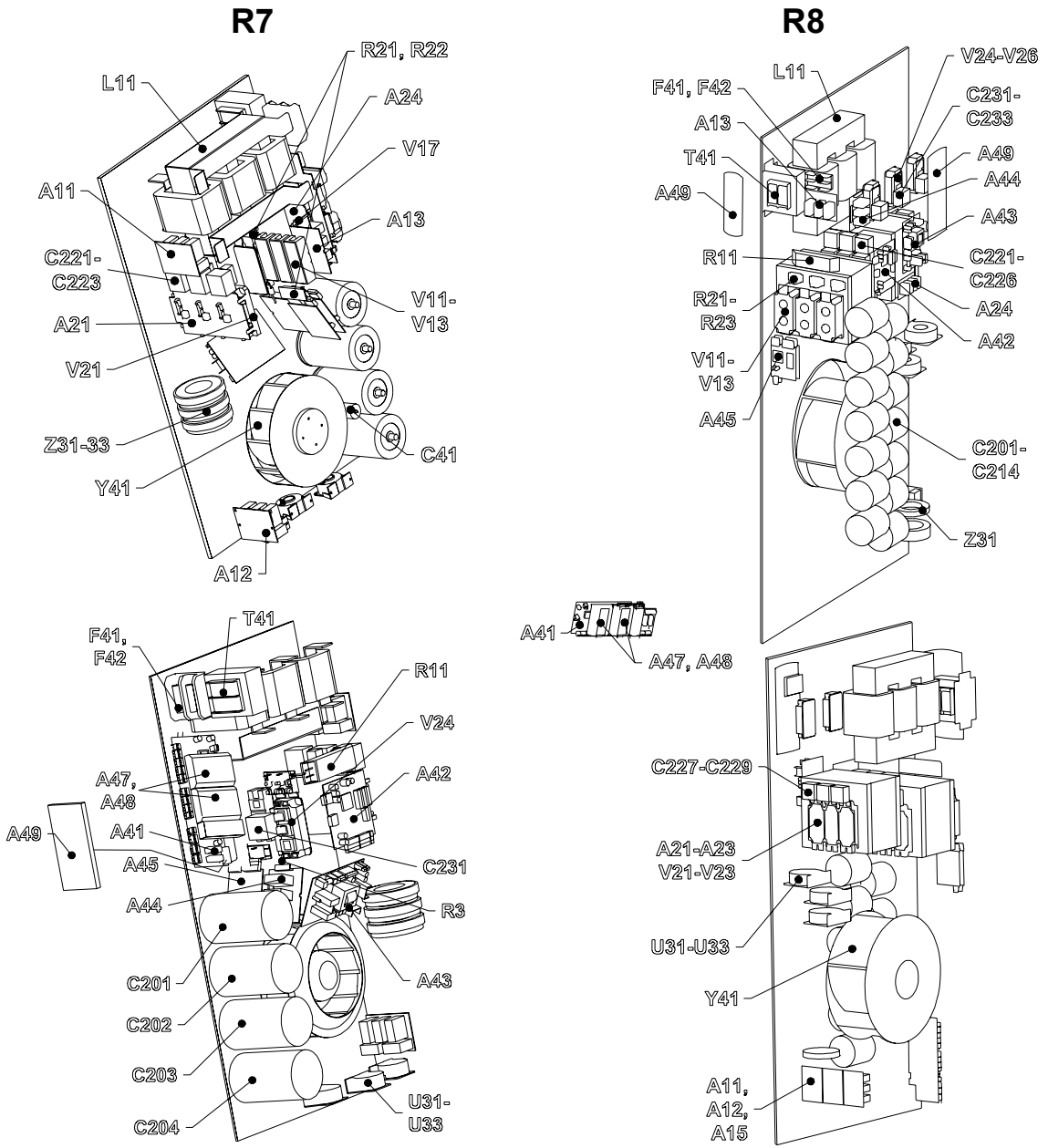

Code: 64572261-B

Code: 64601423-B

Heatsink

The heatsink fins pick up dust from the cooling air. The drive runs into overtemperature warnings and faults if the heatsink is not clean. In a “normal” environment (not dusty, not clean) the heatsink should be checked annually, in a dusty environment more often.

Clean the heatsink as follows (when necessary):

1. Remove the cooling fan (see section [Fan](#)).
2. Blow dry clean compressed air from bottom to top and simultaneously use a vacuum cleaner at the air outlet to trap the dust. **Note:** Prevent dust from entering adjoining equipment.
3. Replace the cooling fan.

Fan

The lifespan of the cooling fan of the drive is about 50 000 hours. The actual lifespan depends on the running time of the fan, ambient temperature and dust concentration. See the appropriate ACS800 firmware manual for the actual signal which indicates the running time of the cooling fan. For resetting the running time signal after a fan replacement, please contact ABB.

A cooling fan is included in the enclosure extension with a contactor option. Its lifespan is at least 40 000 h.

Replacement fans are available from ABB. Do not use other than ABB specified spare parts.

Replacing the fan(s) of the enclosure extension

One or two fans are fastened to the inside of the roof. In addition, a fan is located at the side of the enclosure extension in the largest frame size R8 units for first environment (+E202): with bottom entry/exit at the left-hand side, with top entry/exit at the right-hand side.

Remove the fan as follows:

1. Disconnect the fan wires.
2. Loosen the six fixing screws of the fan cassette.
3. Shift the fan cassette sideways and pull it out of the enclosure extension.
4. Undo the screws that fasten the fan to the base of the cassette.
5. Undo the screws that fasten the fingerguard.
6. Install the new fan in reverse order to the above.

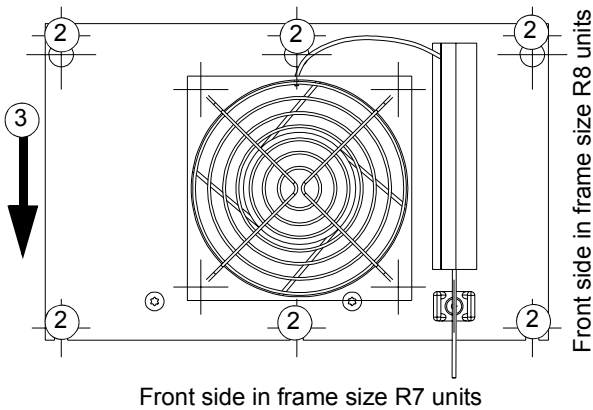

Views from below

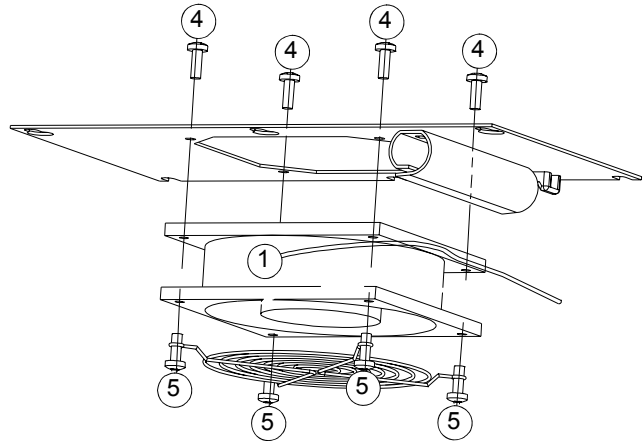

64669800-C

Replacing the fan (R7)

1. Remove the upper front cover and disconnect the control panel cables.
2. Disconnect the discharging resistor wire.
3. Remove the DC capacitor pack by undoing the red fixing screws and pulling the pack out.
4. Disconnect the fan supply wires (detachable connector).
5. Disconnect the fan capacitor wires and remove the fan capacitor.
6. Disconnect the AINP board wires from connectors X1 and X2.
7. Undo the red fixing screws of the fan cassette.
8. Press the snap-on holders to release the side cover.
9. Lift the handle and pull the fan cassette out.
10. Install the new fan and fan capacitor in reverse order to the above.

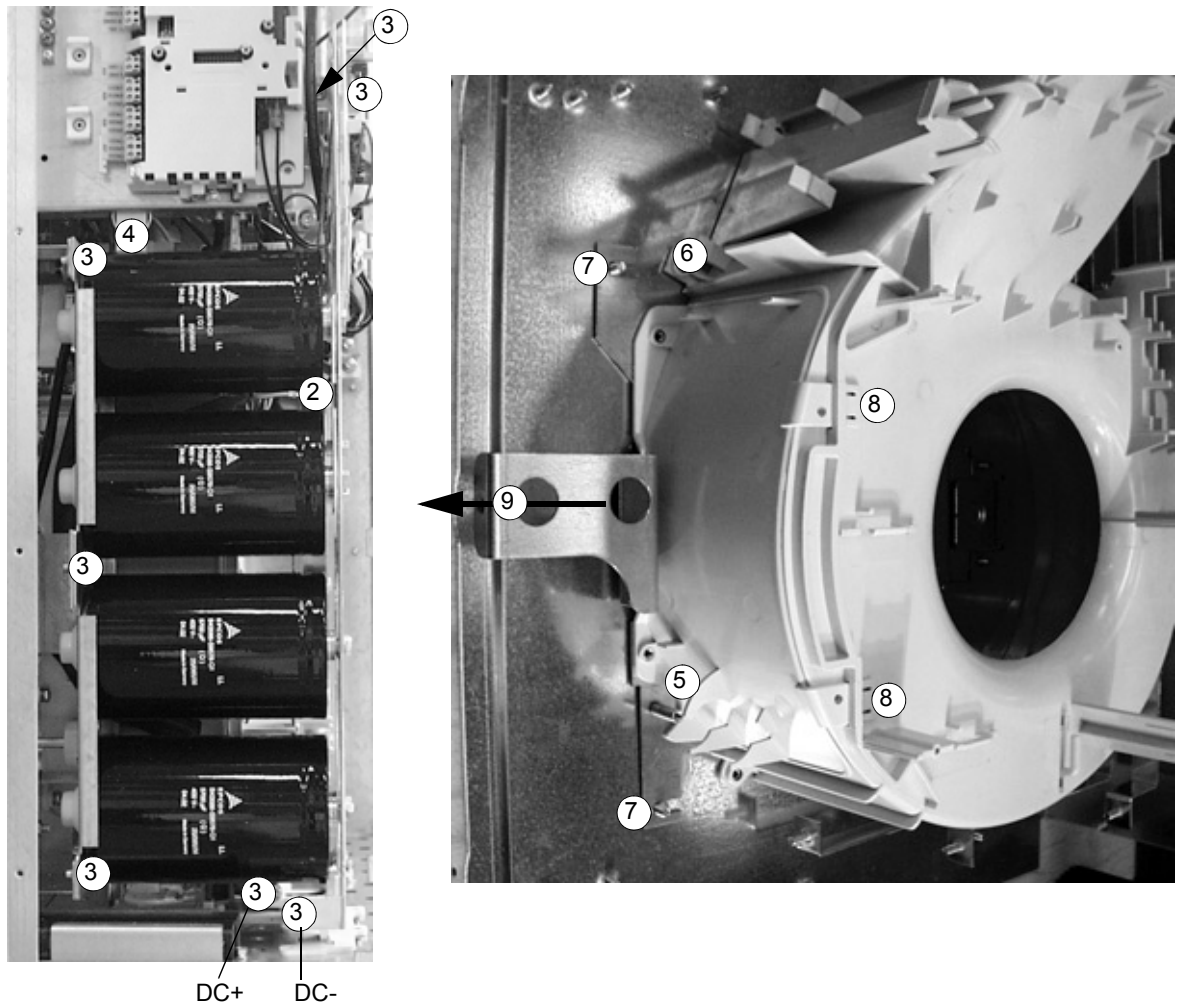

Replacing the fan (R8)

1. Remove the front covers by undoing the fixing screws and disconnecting the control panel cable.
2. Disconnect the fan capacitor and power supply wires.
3. Remove the fan capacitor.
4. Units without enclosure extension: disconnect the power supply (a), fibre optic (b) and control panel (c) cables from the RMIO board.
Units with enclosure extension: move the wires in front of the fan aside.
5. Undo the red fastening screws of the plastic side cover of the fan. Shift the cover to the right to free its right-hand edge and lift the cover off.
6. Undo the red fastening screws of the fan.
7. Lift the fan out.
8. Install the new fan and fan capacitor in reverse order to the above.

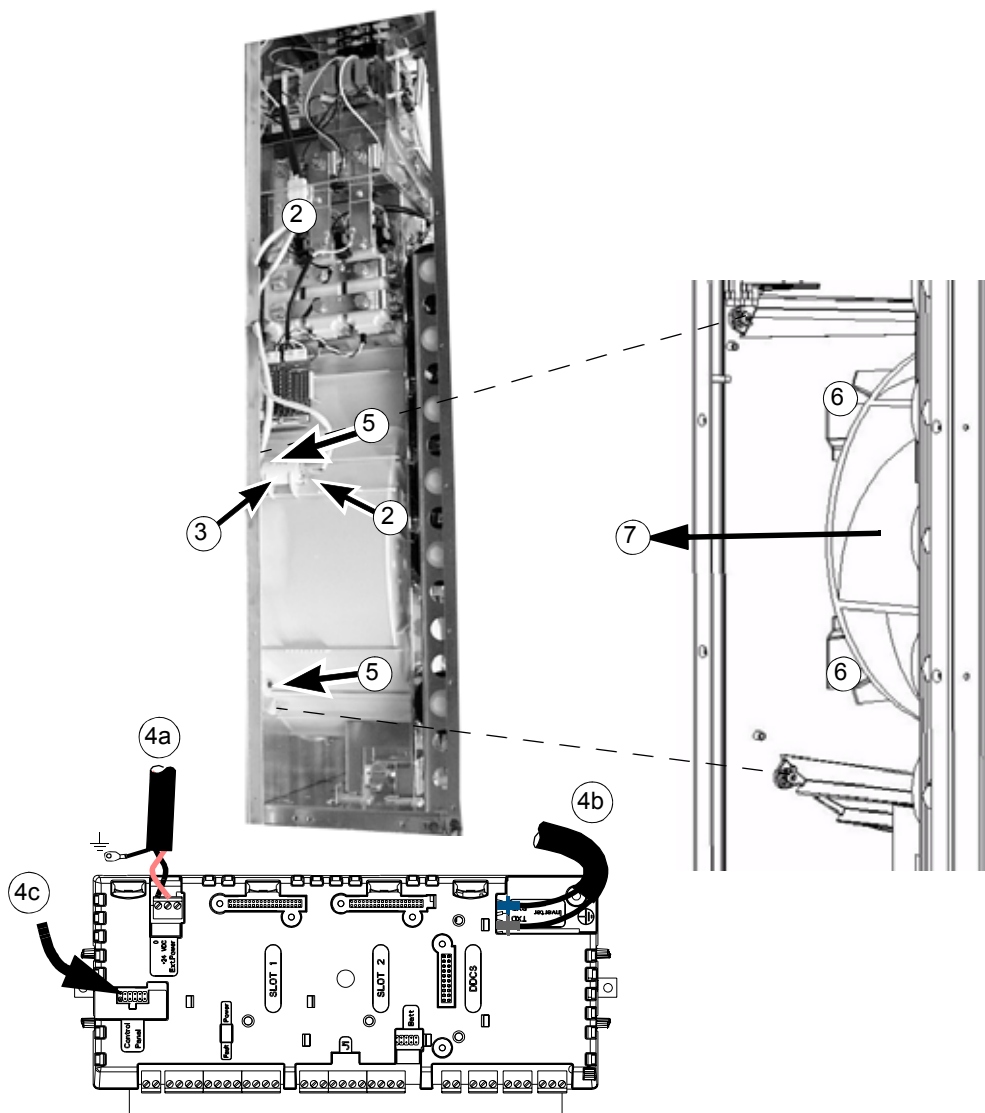

Capacitors

The drive intermediate circuit employs several electrolytic capacitors. Their lifespan is at least 90 000 hours depending on the operating time of the drive, loading and ambient temperature. Capacitor life can be prolonged by lowering the ambient temperature.

It is not possible to predict a capacitor failure. Capacitor failure is usually followed by damage to the unit and an input cable fuse failure, or a fault trip. Contact ABB if capacitor failure is suspected. Replacements are available from ABB. Do not use other than ABB specified spare parts.

Reforming

Reform (re-age) spare part capacitors once a year according to ACS 600/800 *Capacitor Reforming Guide* [code: 3AFE64059629 (English)].

Replacing the capacitor pack (R7)

Replace the capacitor pack as described in section [Replacing the fan \(R7\)](#).

Replacing the capacitor pack (R8)

1. Remove the upper front covers and disconnect the control panel cable. Remove the side plate equipped with the control panel mounting slot.
2. Disconnect the discharging resistor wires.
3. Undo the fastening screws.
4. Lift the capacitor pack out.
5. Install the new capacitor pack in reverse order to the above.

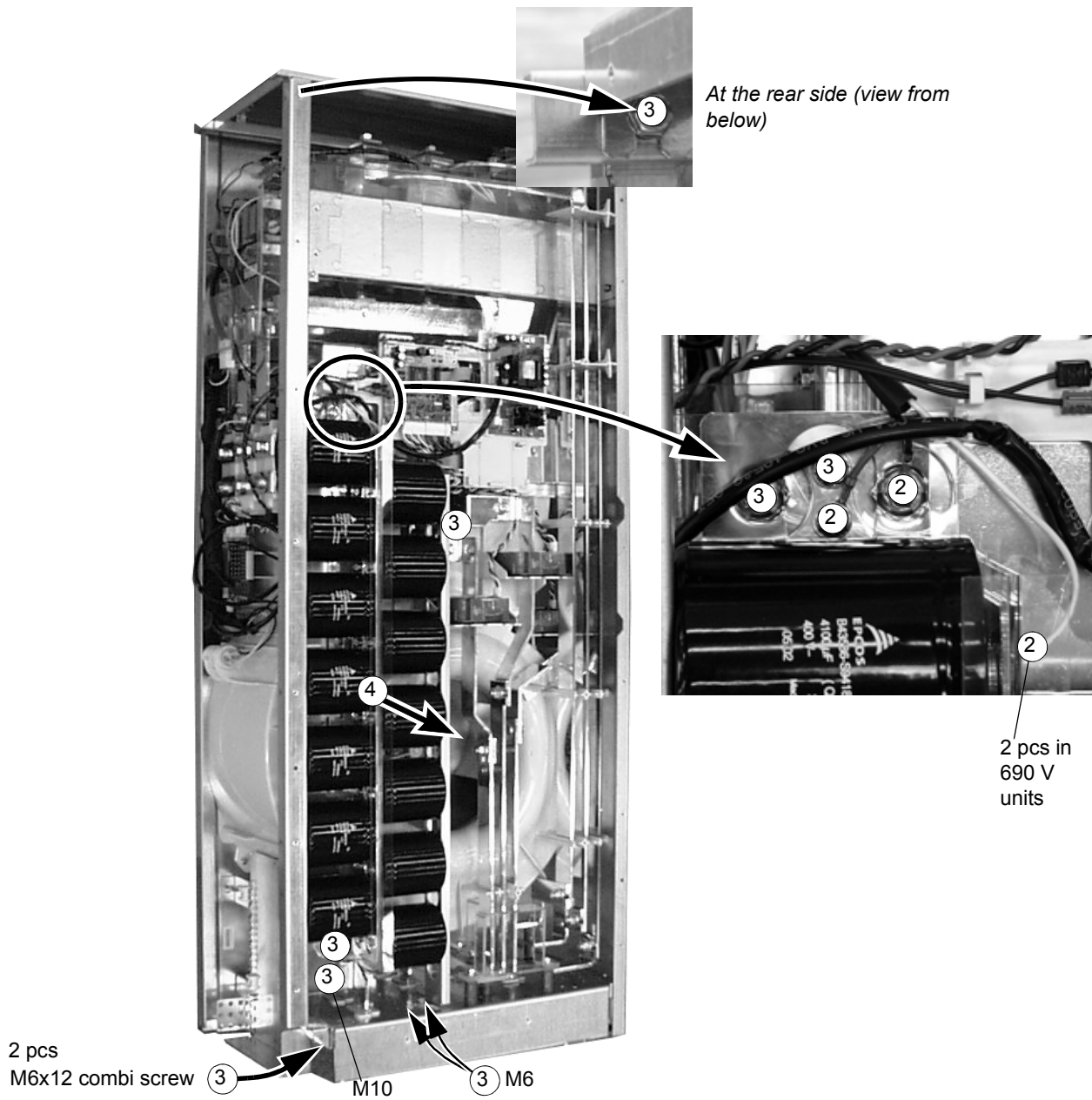

Module replacement of units with the enclosure extension

1. Remove the upper front cover and disconnect the control panel cables.
2. Remove the lower front cover.
3. Undo the fastening screws of the pedestal.
4. Disconnect the pedestal from the drive module by undoing the connection screws. For detailed instructions, see *Installation / Installation procedure / Mounting orientations a and b*.
5. Undo the two screws that fasten the unit to the enclosure extension.
6. Disconnect the power supply wire of the RMIO board and the enclosure extension fan.
7. Disconnect the fibre optic cables of the RMIO board from the AINT board and mark down the terminals for reconnecting.
8. Pull cables 6 and 7 carefully down inside the pedestal and roll them aside so that they will not get damaged when the unit is wheeled out.
9. Wheel the module out.
10. Install the new module in reverse order to the above.

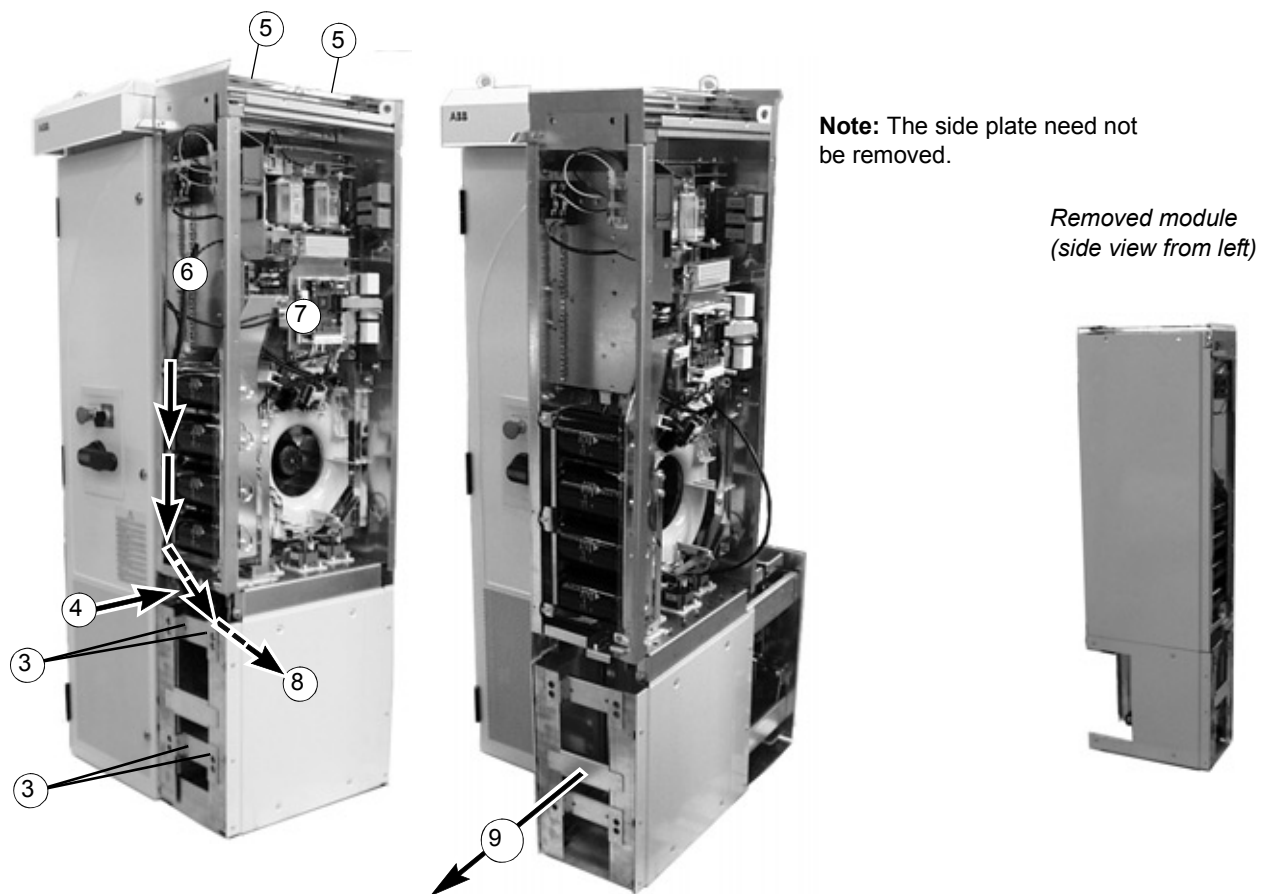

LEDs

This table describes LEDs of the drive.

Where	LED	When the LED is lit
RMIO board	Red	Drive in fault state
	Green	The power supply on the board is OK.
Control panel mounting platform	Red	Drive in fault state
	Green	The main + 24 V power supply for the control panel and the RMIO board is OK.
AINT board	V204 (green)	+5 V voltage of the board is OK.
	V309 (red)	Prevention of Unexpected Start is ON.
	V310 (green)	IGBT control signal transmission to the gate driver control boards is enabled.

Technical data

What this chapter contains

This chapter contains the technical specifications of the drive, e.g. the ratings, sizes and technical requirements, provisions for fulfilling the requirements for CE and other markings, and warranty policy.

IEC data

Ratings

The IEC ratings for the ACS800-02 with 50 Hz and 60 Hz supplies are given below. The symbols are described below the table.

ACS800-02 size	Nominal ratings		No-overload use	Light-overload use		Heavy-duty use		Frame size	Air flow m ³ /h	Heat dissipation W
	$I_{\text{cont.max}}$ A	I_{max} A	$P_{\text{cont.max}}$ kW	I_{2N} A	P_N kW	I_{2hd} A	P_{hd} kW			
Three-phase supply voltage 208 V, 220 V, 230 V or 240 V										
-0080-2	214	326	55	211	55	170	45	R7	540	2900
-0100-2	253	404	75	248	75	202	55	R7	540	3450
-0120-2	295	432	90	290	90	240 ⁴⁾	55	R7	540	4050
-0140-2	405	588	110	396	110	316	90	R8	1220	5300
-0170-2	447	588	132	440	132	340	90	R8	1220	6100
-0210-2	528	588	160	516	160	370	110	R8	1220	6700
-0230-2	613	840	160	598	160	480	132	R8	1220	7600
-0260-2	693	1017	200	679	200	590 ²⁾	160	R8	1220	7850
-0300-2	720	1017	200	704	200	635 ³⁾	200	R8	1220	8300
Three-phase supply voltage 380 V, 400 V or 415 V										
-0140-3	206	326	110	202	110	163	90	R7	540	3000
-0170-3	248	404	132	243	132	202	110	R7	540	3650
-0210-3	289	432	160	284	160	240 ¹⁾	132	R7	540	4300
-0260-3	445	588	200	440	200	340	160	R8	1220	6600
-0320-3	521	588	250	516	250	370	200	R8	1220	7150
-0400-3	602	840	315	590	315	477	250	R8	1220	8100
-0440-3	693	1017	355	679	355	590 ²⁾	315	R8	1220	8650
-0490-3	720	1017	400	704	400	635 ³⁾	355	R8	1220	9100

ACS800-02 size	Nominal ratings		No-overload use	Light-overload use		Heavy-duty use		Frame size	Air flow m ³ /h	Heat dissipation W
	$I_{\text{cont.max}}$ A	I_{max} A		$P_{\text{cont.max}}$ kW	I_{2N} A	P_N kW	$I_{2\text{hd}}$ A			
Three-phase supply voltage 380 V, 400 V, 415 V, 440 V, 460 V, 480 V or 500 V										
-0170-5	196	326	132	192	132	162	110	R7	540	3000
-0210-5	245	384	160	240	160	192	132	R7	540	3800
-0260-5	289	432	200	284	200	224	160	R7	540	4500
-0320-5	440	588	250	435	250	340	200	R8	1220	6850
-0400-5	515	588	315	510	315	370	250	R8	1220	7800
-0440-5	550	840	355	545	355	490	315	R8	1220	7600
-0490-5	602	840	400	590	400	515 ²⁾	355	R8	1220	8100
-0550-5	684	1017	450	670	450	590 ²⁾	400	R8	1220	9100
-0610-5	718	1017	500	704	500	632 ³⁾	450	R8	1220	9700
Three-phase supply voltage 525 V, 550 V, 575 V, 600 V, 660 V or 690 V										
-0140-7	134	190	132	125	110	95	90	R7	540	2800
-0170-7	166	263	160	155	132	131	110	R7	540	3550
-0210-7	166/203*	294	160	165/195*	160*	147	132	R7	540	4250
-0260-7	175/230*	326	160/200*	175/212*	160/200*	163	160	R7	540	4800
-0320-7	315	433	315	290	250	216	200	R8	1220	6150
-0400-7	353	548	355	344	315	274	250	R8	1220	6650
-0440-7	396	656	400	387	355	328	315	R8	1220	7400
-0490-7	445	775	450	426	400	387	355	R8	1220	8450
-0550-7	488	853	500	482	450	426	400	R8	1220	8300
-0610-7	560	964	560	537	500	482	450	R8	1220	9750

PDM code: 00096931-G

- 1) 50% overload is available for one minute every 5 minutes if ambient temperature is less than 25 °C. If ambient temperature is 40 °C, max. available overload is 37%.
 - 2) 50% overload is available for one minute every 5 minutes if ambient temperature is less than 30 °C. If ambient temperature is 40 °C, max. available overload is 40%.
 - 3) 50% overload is available one minute every 5 minutes if ambient temperature is less than 20 °C. If ambient temperature is 40 °C, max. available overload is 30%.
 - 4) 50% overload is available one minute every 5 minutes if ambient temperature is less than 35 °C. If ambient temperature is 40 °C, max. available overload is 45%.
- * higher value applicable if output frequency is above 41 Hz

Symbols

Nominal ratings

$I_{\text{cont.max}}$ continuous rms output current. No overload capability at 40 °C.

I_{max} maximum output current. Available for 10 s at start, otherwise as long as allowed by drive temperature.

Typical ratings:

No-overload use

$P_{\text{cont.max}}$ typical motor power. The power ratings apply to most IEC 34 motors at the nominal voltage, 230 V, 400 V, 500 V or 690 V.

Light-overload use (10% overload capability)

I_{2N} continuous rms current. 10% overload is allowed for one minute every 5 minutes.

P_N typical motor power. The power ratings apply to most IEC 34 motors at the nominal voltage, 230 V, 400 V, 500 V or 690 V.

Heavy-duty use (50% overload capability)

I_{2hd} continuous rms current. 50% overload is allowed for one minute every 5 minutes.

P_{hd} typical motor power. The power ratings apply to most IEC 34 motors at the nominal voltage, 230 V, 400 V, 500 V or 690 V.

Sizing

The current ratings are the same regardless of the supply voltage within one voltage range. To achieve the rated motor power given in the table, the rated current of the drive must be higher than or equal to the rated motor current.

Note 1: The maximum allowed motor shaft power is limited to $1.5 \cdot P_{hd}$, $1.1 \cdot P_N$ or $P_{\text{cont.max}}$ (whichever value is greatest). If the limit is exceeded, motor torque and current are automatically restricted. The function protects the input bridge of the drive against overload. If the condition exists for 5 minutes, the limit is set to $P_{\text{cont.max}}$.

Note 2: The ratings apply at an ambient temperature of 40 °C (104 °F). At lower temperatures the ratings are higher (except I_{max}).

Note 3: Use the DriveSize PC tool for a more accurate dimensioning if the ambient temperature is below 40 °C (104 °F) or the drive is loaded cyclically.

Derating

The load capacity (current and power) decreases if the installation site altitude exceeds 1000 metres (3281 ft), or if the ambient temperature exceeds 40 °C (104 °F).

Temperature derating

In the temperature range +40 °C (+104 °F) to +50 °C (+122 °F), the rated output current is decreased 1% for every additional 1 °C (1.8 °F). The output current is calculated by multiplying the current given in the rating table by the derating factor.

Example If the ambient temperature is 50 °C (+122 °F), the derating factor is $100\% - 1 \frac{\%}{\text{°C}} \cdot 10 \text{ °C} = 90\%$ or 0.90. The output current is then $0.90 \cdot I_{2N}$, $0.90 \cdot I_{2hd}$ or $0.90 \cdot I_{\text{cont.max}}$.

Altitude derating

At altitudes from 1000 to 4000 m (3281 to 13123 ft) above sea level, the derating is 1% for every 100 m (328 ft). For a more accurate derating, use the DriveSize PC tool. See [Installation sites above 2000 metres \(6562 feet\)](#) on page 48.

Fuses

gG and aR fuses for protection against short-circuit in the input power cable or drive are listed below. Either fuse type may be used if it operates rapidly enough. Choose between gG and aR fuses according to the table under [Quick guide for selecting between gG and aR fuses](#) on page 116, or verify the operating time by **checking that the short-circuit current of the installation is at least the value given in the fuse table**. The short-circuit current can be calculated as follows:

$$I_{k2-ph} = \frac{U}{2 \cdot \sqrt{R_c^2 + (Z_k + X_c)^2}}$$

where

I_{k2-ph} = short-circuit current in symmetrical two-phase short-circuit (A)

U = network line-to-line voltage (V)

R_c = cable resistance (ohm)

$Z_k = z_k \cdot U_N^2 / S_N$ = transformer impedance (ohm)

z_k = transformer impedance (%)

U_N = transformer rated voltage (V)

S_N = nominal apparent power of the transformer (kVA)

X_c = cable reactance (ohm).

Calculation example

Drive:

- ACS800-02-0260-3
- supply voltage $U = 410$ V

Transformer:

- rated power $S_N = 3000$ kVA
- rated voltage (drive supply voltage) $U_N = 430$ V
- transformer impedance $z_k = 7.2\%$.

Supply cable:

- length = 170 m
- resistance/length = 0.112 ohm/km
- reactance/length = 0.0273 ohm/km.

$$Z_k = z_k \cdot \frac{U_N^2}{S_N} = 0.072 \cdot \frac{(430 \text{ V})^2}{3000 \text{ kVA}} = 4.438 \text{ mohm}$$

$$R_c = 170 \text{ m} \cdot 0.112 \frac{\text{ohm}}{\text{km}} = 19.04 \text{ mohm}$$

$$X_c = 170 \text{ m} \cdot 0.0273 \frac{\text{ohm}}{\text{km}} = 4.641 \text{ mohm}$$

$$I_{k2-ph} = \frac{410 \text{ V}}{2 \cdot \sqrt{(19.04 \text{ mohm})^2 + (4.438 \text{ mohm} + 4.641 \text{ mohm})^2}} = 9.7 \text{ kA}$$

The calculated short-circuit current 9.7 kA is higher than the minimum short-circuit current of the drive gG fuse type OFAF3H500 (8280 A). -> The 500 V gG fuse (ABB Control OFAF3H500) can be used.

Fuse tables

Ultrarapid (aR) fuses								
ACS800-02 size	Input current A	Min. short-circuit current ¹⁾ A	Fuse					
			A	A ² s	V	Manufacturer	Type DIN 43620 	Size
Three-phase supply voltage 208 V, 220 V, 230 V or 240 V								
-0080-2	201	1810	400	105 000	690	Bussmann	170M3819	DIN1*
-0100-2	239	2210	500	145 000	690	Bussmann	170M5810	DIN2*
-0120-2	285	2620	550	190 000	690	Bussmann	170M5811	DIN2*
-0140-2	391	4000	800	465 000	690	Bussmann	170M6812	DIN3
-0170-2	428	4000	800	465 000	690	Bussmann	170M6812	DIN3
-0210-2	506	5550	1000	945 000	690	Bussmann	170M6814	DIN3
-0230-2	599	7800	1250	1 950 000	690	Bussmann	170M8554	DIN3
-0260-2	677	8850	1400	3 900 000	690	Bussmann	170M8555	DIN3
-0300-2	707	8850	1400	3 900 000	690	Bussmann	170M8555	DIN3
Three-phase supply voltage 380 V, 400 V or 415 V								
-0140-3	196	1810	400	105 000	690	Bussmann	170M3819	DIN1*
-0170-3	237	2210	500	145 000	690	Bussmann	170M5810	DIN2*
-0210-3	286	2620	550	190 000	690	Bussmann	170M5811	DIN2*
-0260-3	438	4000	800	465 000	690	Bussmann	170M6812	DIN3
-0320-3	501	5550	1000	945 000	690	Bussmann	170M6814	DIN3
-0400-3	581	7800	1250	1 950 000	690	Bussmann	170M8554	DIN3
-0440-3	674	8850	1400	3 900 000	690	Bussmann	170M8555	DIN3
-0490-3	705	8850	1400	3 900 000	690	Bussmann	170M8555	DIN3
Three-phase supply voltage 380 V, 400 V, 415 V, 440 V, 460 V, 480 V or 500 V								
-0170-5	191	1810	400	105 000	690	Bussmann	170M3819	DIN1*
-0210-5	243	2210	500	145 000	690	Bussmann	170M5810	DIN2*
-0260-5	291	2620	550	190 000	690	Bussmann	170M5811	DIN2*
-0320-5	424	4000	800	465 000	690	Bussmann	170M6812	DIN3
-0400-5	498	5550	1000	945 000	690	Bussmann	170M6814	DIN3
-0440-5	543	7800	1250	1 950 000	690	Bussmann	170M8554	DIN3
-0490-5	590	7800	1250	1 950 000	690	Bussmann	170M8554	DIN3
-0550-5	669	8850	1400	3 900 000	690	Bussmann	170M8555	DIN3
-0610-5	702	8850	1400	3 900 000	690	Bussmann	170M8555	DIN3

Ultraprapid (aR) fuses								
ACS800-02 size	Input current A	Min. short-circuit current ¹⁾ A	Fuse					
			A	A ² s	V	Manufacturer	Type DIN 43620 	Size
Three-phase supply voltage 525 V, 550 V, 575 V, 600 V, 660 V or 690 V								
-0140-7	126	1520	350	68 500	690	Bussmann	170M3818	DIN1*
-0170-7	156	1520	350	68 500	690	Bussmann	170M3818	DIN1*
-0210-7	191	1610	400	74 000	690	Bussmann	170M5808	DIN2*
-0260-7	217	1610	400	74 000	690	Bussmann	170M5808	DIN2*
-0320-7	298	3010	630	275 000	690	Bussmann	170M5812	DIN2*
-0400-7	333	2650	630	210 000	690	Bussmann	170M6810	DIN2*
-0440-7	377	4000	800	465 000	690	Bussmann	170M6812	DIN3
-0490-7	423	4790	900	670 000	690	Bussmann	170M6813	DIN3
-0550-7	468	4790	900	670 000	690	Bussmann	170M6813	DIN3
-0610-7	533	5550	1000	945 000	690	Bussmann	170M6814	DIN3
<p>A²s value for -7 units at 660 V</p> <p>¹⁾ minimum short-circuit current of the installation</p> <p>Note 1: See also <i>Planning the electrical installation: Thermal overload and short-circuit protection</i>. For UL recognized fuses, see <i>NEMA data</i> on page 119.</p> <p>Note 2: In multicable installations, install only one fuse per phase (not one fuse per conductor).</p> <p>Note 3: Larger fuses than the recommended ones must not be used.</p> <p>Note 4: Fuses from other manufacturers can be used if they meet the ratings and the melting curve of the fuse does not exceed the melting curve of the fuse mentioned in the table.</p>								

PDM code: 00096931-G, 00556489

gG fuses								
ACS800-02 size	Input current A	Min. short-circuit current ¹⁾ A	Fuse					
			A	A ² s	V	Manufacturer	Type	IEC size
Three-phase supply voltage 208 V, 220 V, 230 V or 240 V								
-0080-2	201	3820	250	550 000	500	ABB Control	OFAF1H250	1
-0100-2	239	4510	315	1 100 000	500	ABB Control	OFAF2H315	2
-0120-2	285	4510	315	1 100 000	500	ABB Control	OFAF2H315	2
-0140-2	391	8280	500	2 900 000	500	ABB Control	OFAF3H500	3
-0170-2	428	8280	500	2 900 000	500	ABB Control	OFAF3H500	3
-0210-2	506	10200	630	4 000 000	500	ABB Control	OFAF3H630	3
-0230-2	599	10200	630	4 000 000	500	ABB Control	OFAF3H630	3
-0260-2	677	13500	800	7 400 000	500	ABB Control	OFAF3H800	3
-0300-2	707	13500	800	7 400 000	500	ABB Control	OFAF3H800	3
Three-phase supply voltage 380 V, 400 V or 415 V								
-0140-3	196	3820	250	550 000	500	ABB Control	OFAF1H250	1
-0170-3	237	4510	315	1 100 000	500	ABB Control	OFAF2H315	2
-0210-3	286	4510	315	1 100 000	500	ABB Control	OFAF2H315	2
-0260-3	438	8280	500	2 900 000	500	ABB Control	OFAF3H500	3
-0320-3	501	10200	630	4 000 000	500	ABB Control	OFAF3H630	3
-0400-3	581	10200	630	4 000 000	500	ABB Control	OFAF3H630	3
-0440-3	674	13500	800	7 400 000	500	ABB Control	OFAF3H800	3
-0490-3	705	13500	800	7 400 000	500	ABB Control	OFAF3H800	3

gG fuses								
ACS800-02 size	Input current A	Min. short-circuit current ¹⁾ A	Fuse					
			A	A ² s	V	Manufacturer	Type	IEC size
Three-phase supply voltage 380 V, 400 V, 415 V, 440 V, 460 V, 480 V or 500 V								
-0170-5	191	3820	250	550 000	500	ABB Control	OFAF1H250	1
-0210-5	243	4510	315	1 100 000	500	ABB Control	OFAF2H315	2
-0260-5	291	4510	315	1 100 000	500	ABB Control	OFAF2H315	2
-0320-5	424	8280	500	2 900 000	500	ABB Control	OFAF3H500	3
-0400-5	498	10200	630	4 000 000	500	ABB Control	OFAF3H630	3
-0440-5	543	10200	630	4 000 000	500	ABB Control	OFAF3H630	3
-0490-5	590	10200	630	4 000 000	500	ABB Control	OFAF3H630	3
-0550-5	669	13500	800	7 400 000	500	ABB Control	OFAF3H800	3
-0610-5	702	13500	800	7 400 000	500	ABB Control	OFAF3H800	3
Three-phase supply voltage 525 V, 550 V, 575 V, 600 V, 660 V or 690 V								
-0140-7	126	2400	160	220 000	690	ABB Control	OFAA1GG160	1
-0170-7	156	2850	200	350 000	690	ABB Control	OFAA1GG200	1
-0210-7	191	3820	250	700 000	690	ABB Control	OFAA2GG250	2
-0260-7	217	3820	250	700 000	690	ABB Control	OFAA2GG250	2
-0320-7	298	4510	315	820 000	690	ABB Control	OFAA2GG315	2
-0400-7	333	6180	400	1 300 000	690	ABB Control	OFAA3GG400	3
-0440-7	377	8280	500	3 800 000	690	ABB Control	OFAA3H500	3
-0490-7	423	8280	500	3 800 000	690	ABB Control	OFAA3H500	3
-0550-7	468	8280	500	3 800 000	690	ABB Control	OFAA3H500	3
-0610-7	533	10800	630	10 000 000	690	Bussmann	630NH3G-690 **	3
<p>** rated braking capacity only up to 50 kA</p> <p>¹⁾ minimum short-circuit current of the installation</p> <p>Note 1: See also <i>Planning the electrical installation: Thermal overload and short-circuit protection</i>. For UL recognized fuses, see <i>NEMA data</i> on page 119.</p> <p>Note 2: In multicable installations, install only one fuse per phase (not one fuse per conductor).</p> <p>Note 3: Larger fuses than the recommended ones must not be used.</p> <p>Note 4: Fuses from other manufacturers can be used if they meet the ratings and the melting curve of the fuse does not exceed the melting curve of the fuse mentioned in the table.</p>								

PDM code: 00096931-G, 00556489

Quick guide for selecting between gG and aR fuses

The table below is a short cut in selecting between gG and aR fuses. The combinations (cable size, cable length, transformer size and fuse type) in the table fulfil the minimum requirements for the proper operation of the fuse.

ACS800-02 size	Cable type		Supply transformer minimum apparent power S_N (kVA)					
	Copper	Aluminium	Maximum cable length with gG fuses			Maximum cable length with aR fuses		
			10 m	50 m	100 m	10 m	100 m	200 m
Three-phase supply voltage 208 V, 220 V, 230 V or 240 V								
-0080-2	3×120 Cu	3×185 Al	120	150	-	81	81	-
-0100-2	3×150 Cu	3×240 Al	140	170	-	96	96	-
-0120-2	3×240 Cu	2 × (3×95) Al	140	170	-	120	120	-
-0140-2	2 × (3×120) Cu	3 × (3×95) Al	250	320	-	160	160	-
-0170-2	2 × (3×120) Cu	3 × (3×95) Al	250	320	-	180	180	-
-0210-2	3 × (3×95) Cu	2 × (3×240) Al	310	400	-	210	230	-
-0230-2	3 × (3×120) Cu	3 × (3×185) Al	310	400	-	240	340	-
-0260-2	3 × (3×150) Cu	3 × (3×240) Al	410	510	-	270	380	-
-0300-2	3 × (3×150) Cu	3 × (3×240) Al	410	510	-	290	380	-
Three-phase supply voltage 380 V, 400 V or 415 V								
-0140-3	3×120 Cu	3×185 Al	200	220	260	160	160	160
-0170-3	3×150 Cu	3×240 Al	240	260	310	170	170	170
-0210-3	3×240 Cu	2 × (3×120) Al	240	260	310	200	200	200
-0260-3	3 × (3×70) Cu	3 × (3×120) Al	430	460	560	310	310	310
-0320-3	3 × (3×95) Cu	2 × (3×240) Al	530	600	750	350	350	440
-0400-3	3 × (3×120) Cu	3 × (3×185) Al	530	600	750	410	470	660
-0440-3	3 × (3×150) Cu	3 × (3×240) Al	700	770	930	470	530	730
-0490-3	3 × (3×150) Cu	3 × (3×240) Al	700	770	930	490	530	730
Three-phase supply voltage 380 V, 400 V, 415 V, 440 V, 460 V, 480 V or 500 V								
-0170-5	3×120 Cu	3×150 Al	250	270	310	200	200	200
-0210-5	3×150 Cu	3×240 Al	290	320	360	220	220	220
-0260-5	3×240 Cu	2 × (3×120) Al	290	320	360	260	260	260
-0320-5	2 × (3×120) Cu	3 × (3×95) Al	530	570	670	370	370	370
-0400-5	2 × (3×150) Cu	2 × (3×240) Al	660	720	840	440	440	480
-0440-5	3 × (3×95) Cu	3 × (3×150) Al	660	720	840	500	570	760
-0490-5	3 × (3×120) Cu	3 × (3×185) Al	660	720	840	520	570	760
-0550-5	2 × (3×240) Cu	3 × (3×240) Al	880	980	1200	580	670	880
-0610-5	3 × (3×150) Cu	3 × (3×240) Al	880	980	1200	610	670	880
Three-phase supply voltage 525 V, 550 V, 575 V, 600 V, 660 V or 690 V								
-0140-7	3×70 Cu	3×95 Al	220	220	240	160	160	160
-0170-7	3×95 Cu	3×120 Al	260	260	280	190	190	190
-0210-7	3×120 Cu	3×150 Al	340	360	390	230	230	230
-0260-7	3×150 Cu	3×185 Al	340	360	390	260	260	260
-0320-7	3×240 Cu	2 × (3×120) Al	400	410	430	360	360	360
-0400-7	3×240 Cu	3 × (3×70) Al	550	570	610	400	400	400
-0440-7	2 × (3×120) Cu	2 × (3×150) Al	730	780	860	460	460	460
-0490-7	2 × (3×120) Cu	3 × (3×95) Al	730	780	860	510	510	510
-0550-7	2 × (3×150) Cu	3 × (3×120) Al	730	780	860	560	560	560
-0610-7	3 × (3×95) Cu	3 × (3×150) Al	960	1000	1100	640	640	640

PDM code: 00556489 A

Note 1: The supply transformer minimum power in kVA is calculated with a z_k value of 6% and frequency 50 Hz.

Note 2: The table is not intended for transformer selection - that must be done separately.

The following parameters can effect on the correct operation of the protection:

- cable length, i.e. the longer the cable the weaker the fuse protection, as the long cable limits the fault current
- cable size, i.e. the smaller the cable cross-section the weaker the fuse protection, as the small cable size limits the fault current
- transformer size, i.e the smaller the transformer the weaker the fuse protection, as the small transformer limits the fault current
- transformer impedance, i.e. the higher the z_k the weaker the fuse protection as high impedance limits the fault current.

The protection can be improved by installing a bigger supply transformer and/or bigger cables, and in most cases by selecting aR fuses instead of gG fuses. Selection of smaller fuses improves the protection, but may also affect the fuse life time and lead to unnecessary operation of the fuses.

In case of any uncertainty regarding the drive protection, please contact your local ABB.

Cable types

The table below gives copper and aluminium cable types for different load currents. Cable sizing is based on max. 9 cables laid on a cable ladder side by side, ambient temperature 30 °C, PVC insulation, surface temperature 70 °C (EN 60204-1 and IEC 60364-5-52/2001). For other conditions, size the cables according to local safety regulations, appropriate input voltage and the load current of the drive.

Copper cables with concentric copper shield		Aluminium cables with concentric copper shield	
Max. load current A	Cable type mm ²	Max. load current A	Cable type mm ²
56	3×16	69	3×35
71	3×25	83	3×50
88	3×35	107	3×70
107	3×50	130	3×95
137	3×70	151	3×120
167	3×95	174	3×150
193	3×120	199	3×185
223	3×150	235	3×240
255	3×185	214	2 × (3×70)
301	3×240	260	2 × (3×95)
274	2 × (3×70)	302	2 × (3×120)
334	2 × (3×95)	348	2 × (3×150)
386	2 × (3×120)	398	2 × (3×185)
446	2 × (3×150)	470	2 × (3×240)
510	2 × (3×185)	522	3 × (3×150)
602	2 × (3×240)	597	3 × (3×185)
579	3 × (3×120)	705	3 × (3×240)
669	3 × (3×150)		
765	3 × (3×185)		
903	3 × (3×240)		

3BFA 01051905 C

Cable entries

Mains, motor and brake resistor cable terminal sizes (per phase), maximum accepted cable diameters and tightening torques are given below. The maximum allowed width of the cable lug is 38 mm.

Frame size	U1, V1, W1, U2, V2, W2, UDC+/R+, UDC-, R-				Earthing PE	
	Number of holes per phase	Cable Ø mm	Screw	Tightening torque Nm	Screw	Tightening torque Nm
R7	2	58	M12	50...75	M8*	15...22
R8	3	58	M12	50...75	M8*	15...22

* M10 in the enclosure extension, tightening torque 30...44 Nm

Dimensions, weights and noise

Frame size	IP 21				W3 kg	W4 kg	Noise dB
	H mm	W1 mm	W2 mm	Depth mm			
R7	1507	250	602	524	110	195	71
R8	2024	347	793	622	240	375	72

H height without lifting lugs

W1 width of the basic unit

W2 width with the optional enclosure extension

W3 weight of the basic unit

W4 weight with the optional enclosure extension (basic configuration with switch fuse but without contactor and other options).

NEMA data

Ratings

The NEMA ratings for the ACS800-U2 and ACS800-02 with 60 Hz supplies are given below. The symbols are described below the table. For sizing, derating and 50 Hz supplies, see [IEC data](#).

ACS800-U2 size ACS800-02 size	I_{max} A	Normal use		Heavy-duty use		Frame size	Air flow ft ³ /min	Heat dissipation BTU/Hr
		I_{2N} A	P_N HP	I_{2hd} A	P_{hd} HP			
Three-phase supply voltage 208 V, 220 V, 230 V or 240 V								
-0080-2	326	211	75	170	60	R7	318	9900
-0100-2	404	248	100	202	75	R7	318	11750
-0120-2	432	290	100	240 ⁴⁾	75	R7	318	13750
-0140-2	588	396	150	316	125	R8	718	18100
-0170-2	588	440	150	340	125	R8	718	20800
-0210-2	588	516	200	370	150	R8	718	22750
-0230-2	840	598	200	480	200	R8	718	25900
-0260-2	1017	679	250	590 ³⁾	200	R8	718	26750
-0300-2	1017	704	250	635 ³⁾	250	R8	718	28300
Three-phase supply voltage 380 V, 400 V, 415 V, 440 V, 460 V , 480 V								
-0170-5	326	192	150	162	125	R7	318	10100
-0210-5	384	240	200	192	150	R7	318	12900
-0260-5	432	289 ¹⁾	250 ²⁾	224	150	R7	318	15300
-0270-5 **	480	316	250	240	200	R8	718	23250
-0300-5 **	568	361	300	302	250	R8	718	26650
-0320-5	588	435	350	340	250	R8	718	25950
-0400-5	588	510	400	370	300	R8	718	27600
-0440-5	840	545	450	490	400	R8	718	31100
-0490-5	840	590	500	515 ³⁾	450	R8	718	33000
-0550-5	1017	670	550	590 ³⁾	500	R8	718	31100
-0610-5	1017	718 ⁴⁾	600	590 ³⁾	500	R8	718	33000
Three-phase supply voltage 525 V, 575 V or 600 V								
-0140-7	190	125	125	95	100 ²⁾	R7	318	9600
-0170-7	263	155	150	131	125	R7	318	12150
-0210-7	294	165/195*	150/200*	147	150	R7	318	14550
-0260-7	326	175/212*	150/200*	163	150	R7	318	16400
-0320-7	433	290	300	216	200	R8	718	21050
-0400-7	548	344	350	274	250	R8	718	22750
-0440-7	656	387	400	328	350	R8	718	25450
-0490-7	775	426	450	387	400	R8	718	28900
-0550-7	853	482	500	426	450	R8	718	31250
-0610-7	964	537	500	482	500	R8	718	33300

PDM code: 00096931-G

1) available if ambient temperature is less than 30 °C (86 °F). If ambient temperature is 40 °C (104 °F), I_{2N} is 286 A.

2) special 4-pole high-efficiency NEMA motor

- 3) 50% overload is allowed for one minute every five minutes if ambient temperature is less than 30 °C. 40% overload is allowed if ambient temperature is 40 °C.
- 4) available if ambient temperature is less than 30 °C (86 °F). If ambient temperature is 40 °C (104 °F), I_{2N} is 704 A.
- * higher value available if output frequency is above 41 Hz
- ** ACS800-U2 types only

Symbols

I_{max} maximum output current. Available for 10 s at start, otherwise as long as allowed by drive temperature.

Normal use (10% overload capability)

I_{2N} continuous rms current. 10% overload is typically allowed for one minute every 5 minutes.

P_N typical motor power. The power ratings apply to most 4-pole NEMA rated motors (230 V, 460 V or 575 V).

Heavy-duty use (50% overload capability)

I_{2hd} continuous rms current. 50% overload is typically allowed for one minute every 5 minutes.

P_{hd} typical motor power. The power ratings apply to most 4-pole NEMA rated motors (230 V, 460 V or 575 V).

Note: The ratings apply at an ambient temperature of 40 °C (104 °F). At lower temperatures the ratings are higher.

Sizing

See page [111](#).

Derating

See page [111](#).

Fuses

UL class T or L fuses for branch circuit protection per NEC are listed below. Fast acting class T or faster fuses are recommended in the USA.

Check from the fuse time-current curve that the operating time of the fuse is below 0.1 seconds. The operating time depends on the supply network impedance and the cross-sectional area and length of the supply cable. The short-circuit current can be calculated as shown in section [Fuses](#) on page [112](#).

UL class T and L fuses

ACS800-U2 type	Input current A	Fuse				
		A	V	Manufacturer	Type	UL class
Three-phase supply voltage 208 V, 220 V, 230 V or 240 V						
-0080-2	201	250	600	Bussmann	JJS-250	T
-0100-2	239	300	600	Bussmann	JJS-300	T
-0120-2	285	400	600	Bussmann	JJS-400	T
-0140-2	391	500	600	Bussmann	JJS-500	T
-0170-2	428	600	600	Bussmann	JJS-600	T
-0210-2	506	600	600	Bussmann	JJS-600	T
-0230-2	599	800	600	Ferraz	A4BY800	L
-0260-2	677	800	600	Ferraz	A4BY800	L
-0300-2	707	800	600	Ferraz	A4BY800 ¹⁾	L
Three-phase supply voltage 380 V, 400 V, 415 V, 440 V, 460 V , 480 V						
-0170-5	175	250	600	Bussmann	JJS-250	T
-0210-5	220	300	600	Bussmann	JJS-300	T
-0260-5	267	400	600	Bussmann	JJS-400	T
-0270-5	293	500	600	Bussmann	JJS-500	T
-0300-5	331	500	600	Bussmann	JJS-500	T
-0320-5	397	500	600	Bussmann	JJS-500	T
-0400-5	467	600	600	Bussmann	JJS-600	T
-0440-5	501	800	600	Ferraz	A4BY800	L
-0490-5	542	800	600	Ferraz	A4BY800	L
-0550-5	614	800	600	Ferraz	A4BY800 ¹⁾	L
-0610-5	661	800	600	Ferraz	A4BY800 ¹⁾	L
Three-phase supply voltage 525 V, 575 V or 600 V						
-0140-7	117	200	600	Bussmann	JJS-200	T
-0170-7	146	200	600	Bussmann	JJS-200	T
-0210-7	184	250	600	Bussmann	JJS-250	T
-0260-7	199	300	600	Bussmann	JJS-300	T
-0320-7	273	500	600	Bussmann	JJS-500	T
-0400-7	325	500	600	Bussmann	JJS-500	T
-0440-7	370	500	600	Bussmann	JJS-500	T
-0490-7	407	600	600	Bussmann	JJS-600	T
-0550-7	463	600	600	Bussmann	JJS-600	T
-0610-7	513	700	600	Ferraz	A4BY700	L
¹⁾ 900 A class L fuse A4BY900 must be used for units without enclosure extension Note 1: See also <i>Planning the electrical installation: Thermal overload and short-circuit protection</i> . Note 2: In multicable installations, install only one fuse per phase (not one fuse per conductor). Note 3: Larger fuses than the recommended ones must not be used. Note 4: Fuses from other manufacturers can be used if they meet the ratings and the melting curve of the fuse does not exceed the melting curve of the fuse mentioned in the table.						

PDM code: 00096931-G

Cable types

Cable sizing is based on NEC Table 310-16 for copper wires, 75 °C (167 °F) wire insulation at 40 °C (104 °F) ambient temperature. Not more than three current-carrying conductors in raceway or cable or earth (directly buried). For other conditions, dimension the cables according to local safety regulations, appropriate input voltage and the load current of the drive.

Copper cables with concentric copper shield	
Max. load current	Cable type
A	AWG/kcmil
57	6
75	4
88	3
101	2
114	1
132	1/0
154	2/0
176	3/0
202	4/0
224	250 MCM or 2 x 1
251	300 MCM or 2 x 1/0
273	350 MCM or 2 x 2/0
295	400 MCM or 2 x 2/0
334	500 MCM or 2 x 3/0
370	600 MCM or 2 x 4/0 or 3 x 1/0
405	700 MCM or 2 x 4/0 or 3 x 2/0
449	2 x 250 MCM or 3 x 2/0
502	2 x 300 MCM or 3 x 3/0
546	2 x 350 MCM or 3 x 4/0
590	2 x 400 MCM or 3 x 4/0
669	2 x 500 MCM or 3 x 250 MCM
739	2 x 600 MCM or 3 x 300 MCM
810	2 x 700 MCM or 3 x 350 MCM
884	3 x 400 MCM or 4 x 250 MCM
1003	3 x 500 MCM or 4 x 300 MCM
1109	3 x 600 MCM or 4 x 400 MCM
1214	3 x 700 MCM or 4 x 500 MCM

Cable entries

Input, motor and brake resistor cable terminal sizes (per phase) and tightening torques are given below. For units without enclosure extension, one hole cable lugs (1/2 inch diameter) can be used. The maximum allowed width of the cable lug is 1.5 inches. For units with enclosure extension, two hole cable lugs (1/2 inch diameter) can be used.

Frame size	U1, V1, W1, U2, V2, W2, UDC+/R+, UDC-, R-		Grounding PE	
	Screw	Tightening torque lbf ft	Screw	Tightening torque lbf ft
R7	1/2	37...55	5/16	11...16
R8	1/2	37...55	5/16	11...16

Dimensions, weights and noise

Frame size	UL type 1				W3 lb	W4 lb	Noise dB
	H1 in.	W1 in.	W2 in.	Depth in.			
R7	59.31	9.82	23.70	20.65	243	430	71
R8	79.67	13.66	31.24	24.47	529	827	72

H height without lifting lugs

W1 width of the basic unit

W2 width with the optional enclosure extension

W3 weight of the basic unit

W4 weight with the optional enclosure extension (basic configuration with switch fuse but without contactor and other options).

Input power connection

Voltage (U_1)	208/220/230/240 VAC 3-phase $\pm 10\%$ for 230 VAC units 380/400/415 VAC 3-phase $\pm 10\%$ for 400 VAC units 380/400/415/440/460/480/500 VAC 3-phase $\pm 10\%$ for 500 VAC units 525/550/575/600/660/690 VAC 3-phase $\pm 10\%$ for 690 VAC units				
Short-circuit withstand strength (IEC 60439-1)	Maximum allowable prospective short-circuit current when protected by fuses given in the IEC data fuse tables is for units without enclosure extension: 65 kA (I_{cc}). for units with enclosure extension:				
	<table border="1"> <tr> <td>$I_{cw} / 1 \text{ sec.}$</td> <td>I_{pk}</td> </tr> <tr> <td>50 kA</td> <td>105 kA</td> </tr> </table>	$I_{cw} / 1 \text{ sec.}$	I_{pk}	50 kA	105 kA
$I_{cw} / 1 \text{ sec.}$	I_{pk}				
50 kA	105 kA				
Short-circuit current protection (UL 508, CSA C22.2 No. 14-05)	US and Canada: According to UL 508C (ACS800-U2 without enclosure extension) and UL 508A (ACS800-U2 with enclosure extension), the drive is suitable for use on a circuit capable of delivering not more than 100 kA symmetrical amperes (rms) at 600 V maximum when protected by fuses given in the NEMA data fuse table.				
Frequency	48 to 63 Hz, maximum rate of change 17%/s				
Imbalance	Max. $\pm 3\%$ of nominal phase to phase input voltage				
Fundamental power factor ($\cos \phi_1$)	0.98 (at nominal load)				

Motor connection

Voltage (U_2)	0 to U_1 , 3-phase symmetrical, U_{max} at the field weakening point											
Frequency	DTC mode: 0 to $3.2 \cdot f_{FWP}$. Maximum frequency 300 Hz. $f_{FWP} = \frac{U_{Nmains}}{U_{Nmotor}} \cdot f_{Nmotor}$ f_{FWP} : frequency at field weakening point; U_{Nmains} : mains (input power) voltage; U_{Nmotor} : rated motor voltage; f_{Nmotor} : rated motor frequency											
Frequency resolution	0.01 Hz											
Current	See section IEC data .											
Power limit	$1.5 \cdot P_{hd}$, $1.1 \cdot P_N$ or $P_{cont.max}$ (whichever value is greatest)											
Field weakening point	8 to 300 Hz											
Switching frequency	3 kHz (average). In 690 V units 2 kHz (average).											
Maximum recommended motor cable length	<table border="1"> <thead> <tr> <th rowspan="2">Type code (EMC equipment)</th> <th colspan="2">Max. motor cable length</th> </tr> <tr> <th>DTC control</th> <th>Scalar control</th> </tr> </thead> <tbody> <tr> <td>-</td> <td>300 m (984 ft)</td> <td>300 m (984 ft)</td> </tr> <tr> <td>+E202 *, +E210 *</td> <td>100 m (328 ft)</td> <td>100 m (328 ft)</td> </tr> </tbody> </table> <p>* Motor cable longer than 100 m (328 ft) is allowed but then the EMC Directive requirements may not be fulfilled.</p>	Type code (EMC equipment)	Max. motor cable length		DTC control	Scalar control	-	300 m (984 ft)	300 m (984 ft)	+E202 *, +E210 *	100 m (328 ft)	100 m (328 ft)
Type code (EMC equipment)	Max. motor cable length											
	DTC control	Scalar control										
-	300 m (984 ft)	300 m (984 ft)										
+E202 *, +E210 *	100 m (328 ft)	100 m (328 ft)										

Efficiency

Approximately 98% at nominal power level

Cooling

Method	Internal fan, flow direction from front to top
Free space around the unit	See chapter Installation .
Cooling air flow	See IEC data .

Degrees of protection

IP 21 (UL type 1)

Ambient conditions

Environmental limits for the drive are given below. The drive is to be used in a heated, indoor, controlled environment.

	Operation installed for stationary use	Storage in the protective package	Transportation in the protective package
Installation site altitude	0 to 4000 m (13123 ft) above sea level [above 1000 m (3281 ft), see section <i>Derating</i>]	-	-
Air temperature	-15 to +50 °C (5 to 122 °F). No frost allowed. See section <i>Derating</i> .	-40 to +70 °C (-40 to +158 °F)	-40 to +70 °C (-40 to +158 °F)
Relative humidity	5 to 95%	Max. 95%	Max. 95%
	No condensation allowed. Maximum allowed relative humidity is 60% in the presence of corrosive gases.		
Contamination levels (IEC 60721-3-3, IEC 60721-3-2, IEC 60721-3-1)	No conductive dust allowed.		
	Boards without coating: Chemical gases: Class 3C1 Solid particles: Class 3S2 Boards with coating: Chemical gases: Class 3C2 Solid particles: Class 3S2	Boards without coating: Chemical gases: Class 1C2 Solid particles: Class 1S3 Boards with coating: Chemical gases: Class 1C2 Solid particles: Class 1S3	Boards without coating: Chemical gases: Class 2C2 Solid particles: Class 2S2 Boards with coating: Chemical gases: Class 2C2 Solid particles: Class 2S2
Atmospheric pressure	70 to 106 kPa 0.7 to 1.05 atmospheres	70 to 106 kPa 0.7 to 1.05 atmospheres	60 to 106 kPa 0.6 to 1.05 atmospheres
Vibration (IEC 60068-2)	Max. 1 mm (0.04 in.) (5 to 13.2 Hz), max. 7 m/s ² (23 ft/s ²) (13.2 to 100 Hz) sinusoidal	Max. 1 mm (0.04 in.) (5 to 13.2 Hz), max. 7 m/s ² (23 ft/s ²) (13.2 to 100 Hz) sinusoidal	Max. 3.5 mm (0.14 in.) (2 to 9 Hz), max. 15 m/s ² (49 ft/s ²) (9 to 200 Hz) sinusoidal
Shock (IEC 60068-2-29)	Not allowed	Max. 100 m/s ² (330 ft./s ²), 11 ms	Max. 100 m/s ² (330 ft./s ²), 11 ms
Free fall	Not allowed	100 mm (4 in.) for weight over 100 kg (220 lb)	100 mm (4 in.) for weight over 100 kg (220 lb)

Materials

Drive enclosure	<ul style="list-style-type: none"> PC/ABS 2.5 mm, colour NCS 1502-Y (RAL 90021 / PMS 420 C) hot-dip zinc coated steel sheet 1.5 to 2.5 mm, thickness of coating 100 micrometres, colour NCS 1502-Y
Package	plywood and wood. Plastic covering of the package: PE-LD, bands PP or steel.
Disposal	<p>The drive contains raw materials that should be recycled to preserve energy and natural resources. The package materials are environmentally compatible and recyclable. All metal parts can be recycled. The plastic parts can either be recycled or burned under controlled circumstances, according to local regulations. Most recyclable parts are marked with recycling marks.</p> <p>If recycling is not feasible, all parts excluding electrolytic capacitors and printed circuit boards can be landfilled. The DC capacitors (C1-1 to C1-x) contain electrolyte and the printed circuit boards contain lead, both of which are classified as hazardous waste within the EU. They must be removed and handled according to local regulations.</p> <p>For further information on environmental aspects and more detailed recycling instructions, please contact your local ABB distributor.</p>

Applicable standards

	The drive complies with the following standards. The compliance with the European Low Voltage Directive is verified according to standards EN 61800-5-1 and EN 60204-1.
• EN 61800-5-1 (2003)	Adjustable speed electrical power drive systems. Part 5-1: Safety requirements – electrical, thermal and energy
• EN 60204-1 (2006)	Safety of machinery. Electrical equipment of machines. Part 1: General requirements. <i>Provisions for compliance:</i> The final assembler of the machine is responsible for installing - an emergency-stop device - a supply disconnecting device.
• EN 60529: 1991 (IEC 529)	Degrees of protection provided by enclosures (IP code)
• IEC 60664-1 (2007)	Insulation coordination for equipment within low-voltage systems. Part 1: Principles, requirements and tests.
• EN 61800-3 (2004)	Adjustable speed electrical power drive systems. Part 3: EMC requirements and specific test methods
• UL 508C (2002)	UL Standard for Safety, Power Conversion Equipment, second edition
• NEMA 250 (2003)	Enclosures for Electrical Equipment (1000 Volts Maximum)
• CSA C22.2 No. 14-05 (2005)	Industrial control equipment

US patents

This product is protected by one or more of the following US patents:

4,920,306	5,301,085	5,463,302	5,521,483	5,532,568	5,589,754
5,612,604	5,654,624	5,799,805	5,940,286	5,942,874	5,952,613
6,094,364	6,147,887	6,175,256	6,184,740	6,195,274	6,229,356
6,252,436	6,265,724	6,305,464	6,313,599	6,316,896	6,335,607
6,370,049	6,396,236	6,448,735	6,498,452	6,552,510	6,597,148
6,741,059	6,774,758	6,844,794	6,856,502	6,859,374	6,922,883
6,940,253	6,934,169	6,956,352	6,958,923	6,967,453	6,972,976
6,977,449	6,984,958	6,985,371	6,992,908	6,999,329	7,023,160
7,034,510	7,036,223	7,045,987	7,057,908	7,059,390	7,067,997
7,082,374	7,084,604	7,098,623	7,102,325	D503,931	D510,319
D510,320	D511,137	D511,150	D512,026	D512,696	D521,466.

CE marking

A CE mark is attached to the drive to verify that the unit follows the provisions of the European Low Voltage and EMC Directives (Directive 73/23/EEC, as amended by 93/68/EEC and Directive 89/336/EEC, as amended by 2004/108EC).

Definitions

EMC stands for **E**lectromagnetic **C**ompatibility. It is the ability of electrical/electronic equipment to operate without problems within an electromagnetic environment. Likewise, the equipment must not disturb or interfere with any other product or system within its locality.

First environment includes establishments connected to a low-voltage network which supplies buildings used for domestic purposes.

Second environment includes establishments connected to a network not supplying domestic premises.

Drive of category C2: drive of rated voltage less than 1000 V and intended to be installed and commissioned only by a professional when used in the first environment. **Note:** A professional is a person or organisation having necessary skills in installing and/or commissioning power drive systems, including their EMC aspects.

Drive of category C3: drive of rated voltage less than 1000 V and intended for use in the second environment and not intended for use in the first environment.

Drive of category C4: drive of rated voltage equal to or above 1000 V, or rated current equal to or above 400 A, or intended for use in complex systems in the second environment.

Compliance with the EMC Directive

The EMC Directive defines the requirements for immunity and emissions of electrical equipment used within the European Union. The EMC product standard [EN 61800-3 (2004)] covers requirements stated for drives.

Compliance with the and EN 61800-3 (2004)

First environment (drive of category C2)

The drive complies with the standard with the following provisions:

1. The drive is equipped with EMC filter +E202.
2. The motor and control cables are selected as specified in the *Hardware Manual*.
3. The drive is installed according to the instructions given in the *Hardware Manual*.
4. Maximum cable length is 100 metres.

WARNING! The drive may cause radio interference if used in a residential or domestic environment. The user is required to take measures to prevent interference, in addition to the requirements for CE compliance listed above, if necessary.

Note: It is not allowed to install a drive equipped with EMC filter +E202 on IT (unearthed) systems. The supply network becomes connected to earth potential through the EMC filter capacitors which may cause danger or damage the unit.

Second environment (drive of category C3)

The drive complies with the standard with the following provisions:

1. The drive is equipped with EMC filter +E210. The filter is suitable for TN (earthed) and IT (unearthed) systems.
2. The motor and control cables are selected as specified in the *Hardware Manual*.
3. The drive is installed according to the instructions given in the *Hardware Manual*.
4. Maximum cable length is 100 metres.

WARNING! A drive of category C3 is not intended to be used on a low-voltage public network which supplies domestic premises. Radio frequency interference is expected if the drive is used on such a network.

Second environment (drive of category C4)

If the provisions under [Second environment \(drive of category C3\)](#) cannot be met, the requirements of the standard can be met as follows:

1. It is ensured that no excessive emission is propagated to neighbouring low-voltage networks. In some cases, the inherent suppression in transformers and cables is sufficient. If in doubt, the supply transformer with static screening between the primary and secondary windings can be used.

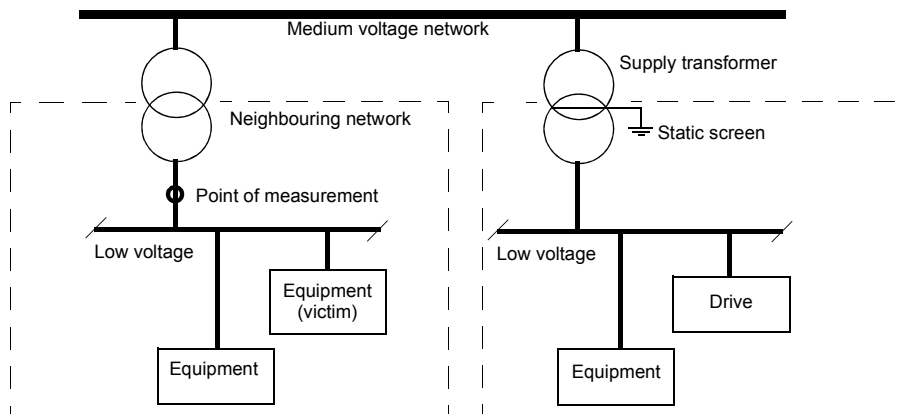

2. An EMC plan for preventing disturbances is drawn up for the installation. A template is available from the local ABB representative.
3. The motor and control cables are selected as specified in the *Hardware Manual*.
4. The drive is installed according to the instructions given in the *Hardware Manual*.

WARNING! A drive of category C4 is not intended to be used on a low-voltage public network which supplies domestic premises. Radio frequency interference is expected if the drive is used on such a network.

Machinery Directive

The drive complies with the European Union Machinery Directive (98/37/EC) requirements for an equipment intended to be incorporated into machinery.

“C-tick” marking

“C-tick” marking is required in Australia and New Zealand. A “C-tick” mark is attached to each drive in order to verify compliance with the relevant standard (IEC 61800-3 (2004) – Adjustable speed electrical power drive systems – Part 3: EMC product standard including specific test methods), mandated by the Trans-Tasman Electromagnetic Compatibility Scheme.

Definitions

EMC stands for **E**lectromagnetic **C**ompatibility. It is the ability of electrical/electronic equipment to operate without problems within an electromagnetic environment. Likewise, the equipment must not disturb or interfere with any other product or system within its locality.

The Trans-Tasman Electromagnetic Compatibility Scheme (EMCS) was introduced by the Australian Communication Authority (ACA) and the Radio Spectrum Management Group (RSM) of the New Zealand Ministry of Economic Development (NZMED) in November 2001. The aim of the scheme is to protect the radiofrequency spectrum by introducing technical limits for emission from electrical/ electronic products.

First environment includes establishments connected to a low-voltage network which supplies buildings used for domestic purposes.

Second environment includes establishments connected to a network not supplying domestic premises.

Drive of category C2: drive of rated voltage less than 1000 V and intended to be installed and commissioned only by a professional when used in the first environment. **Note:** A professional is a person or organisation having necessary skills in installing and/or commissioning power drive systems, including their EMC aspects.

Drive of category C3: drive of rated voltage less than 1000 V and intended for use in the second environment and not intended for use in the first environment.

Drive of category C4: drive of rated voltage equal to or above 1000 V, or rated current equal to or above 400 A, or intended for use in complex systems in the second environment.

Compliance with IEC 61800-3

First environment (drive of category C2)

The drive complies with the limits of IEC 61800-3 with the following provisions:

1. The drive is equipped with EMC filter +E202.
2. The drive is installed according to the instructions given in the *Hardware Manual*.
3. The motor and control cables used are selected as specified in the *Hardware Manual*.
4. Maximum cable length is 100 metres.

WARNING! The drive may cause radio interference if used in a residential or domestic environment. The user is required to take measures to prevent interference, in addition to the requirements for CE compliance listed above, if necessary.

Note: The drive must not be equipped with the EMC filter +E202 when installed to IT (unearthed) systems. The mains becomes connected to earth potential through the EMC filter capacitors. In IT systems this may cause danger or damage the unit.

Second environment (drive of category C3)

The drive complies with the standard with the following provisions:

1. The drive is equipped with EMC filter +E210. The filter is suitable for TN (earthed) and IT (unearthed) systems.
2. The motor and control cables are selected as specified in the *Hardware Manual*.
3. The drive is installed according to the instructions given in the *Hardware Manual*.
4. Maximum cable length is 100 metres.

WARNING! A drive of category C3 is not intended to be used on a low-voltage public network which supplies domestic premises. Radio frequency interference is expected if the drive is used on such a network.

Second environment (drive of category C4)

If the provisions under [Second environment \(drive of category C3\)](#) cannot be met, the requirements of the standard can be met as follows:

1. It is ensured that no excessive emission is propagated to neighbouring low-voltage networks. In some cases, the inherent suppression in transformers and cables is sufficient. If in doubt, the supply transformer with static screening between the primary and secondary windings is strongly recommended.

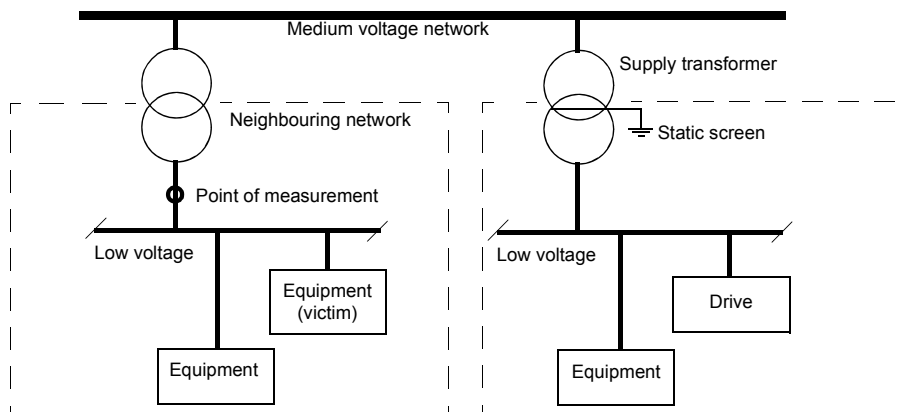

2. An EMC plan for preventing disturbances is drawn up for the installation. A template is available from the local ABB representative.
3. The drive is installed according to the instructions given in the *Hardware Manual*.
4. The motor and control cables used are selected as specified in the *Hardware Manual*.

WARNING! A drive of category C4 is not intended to be used on a low-voltage public network which supplies domestic premises. Radio frequency interference is expected if the drive is used on such a network.

UL/CSA markings

The ACS800-02 and ACS800-U2 are C-UL US listed and CSA marked. The approvals are valid with rated voltages (up to 600 V).

UL

The drive is suitable for use on a circuit capable of delivering not more than 100 kA rms symmetrical amperes at the drive nominal voltage (600 V maximum for 690 V units) when protected by fuses given in the [NEMA data](#) fuse table. The ampere rating is based on tests done according to UL 508.

The drive provides overload protection in accordance with the National Electrical Code (US). See [ACS800 Firmware Manual](#) for setting. Default setting is off, must be activated at start-up.

The drives are to be used in a heated indoor controlled environment. See section [Ambient conditions](#) for specific limits.

Brake chopper - ABB has brake choppers that, when applied with appropriately sized brake resistors, will allow the drive to dissipate regenerative energy (normally associated with quickly decelerating a motor). Proper application of the brake chopper is defined in chapter [Resistor braking](#).

Equipment warranty and liability

The manufacturer warrants the equipment supplied against defects in design, materials and workmanship for a period of twelve (12) months after installation or twenty-four (24) months from date of manufacturing, whichever first occurs. The local ABB office or distributor may grant a warranty period different to the above and refer to local terms of liability as defined in the supply contract.

The manufacturer is not responsible for

- any costs resulting from a failure if the installation, commissioning, repair, alternation, or ambient conditions of the drive do not fulfil the requirements specified in the documentation delivered with the unit and other relevant documentation.
- units subjected to misuse, negligence or accident
- units comprised of materials provided or designs stipulated by the purchaser.

In no event shall the manufacturer, its suppliers or subcontractors be liable for special, indirect, incidental or consequential damages, losses or penalties.

This is the sole and exclusive warranty given by the manufacturer with respect to the equipment and is in lieu of and excludes all other warranties, express or implied, arising by operation of law or otherwise, including, but not limited to, any implied warranties of merchantability or fitness for a particular purpose.

If you have any questions concerning your ABB drive, please contact the local distributor or ABB office. The technical data, information and specifications are valid at the time of printing. The manufacturer reserves the right to modifications without prior notice.

Dimensional drawings

The dimensions are given in millimetres and [inches].

Frame size R7

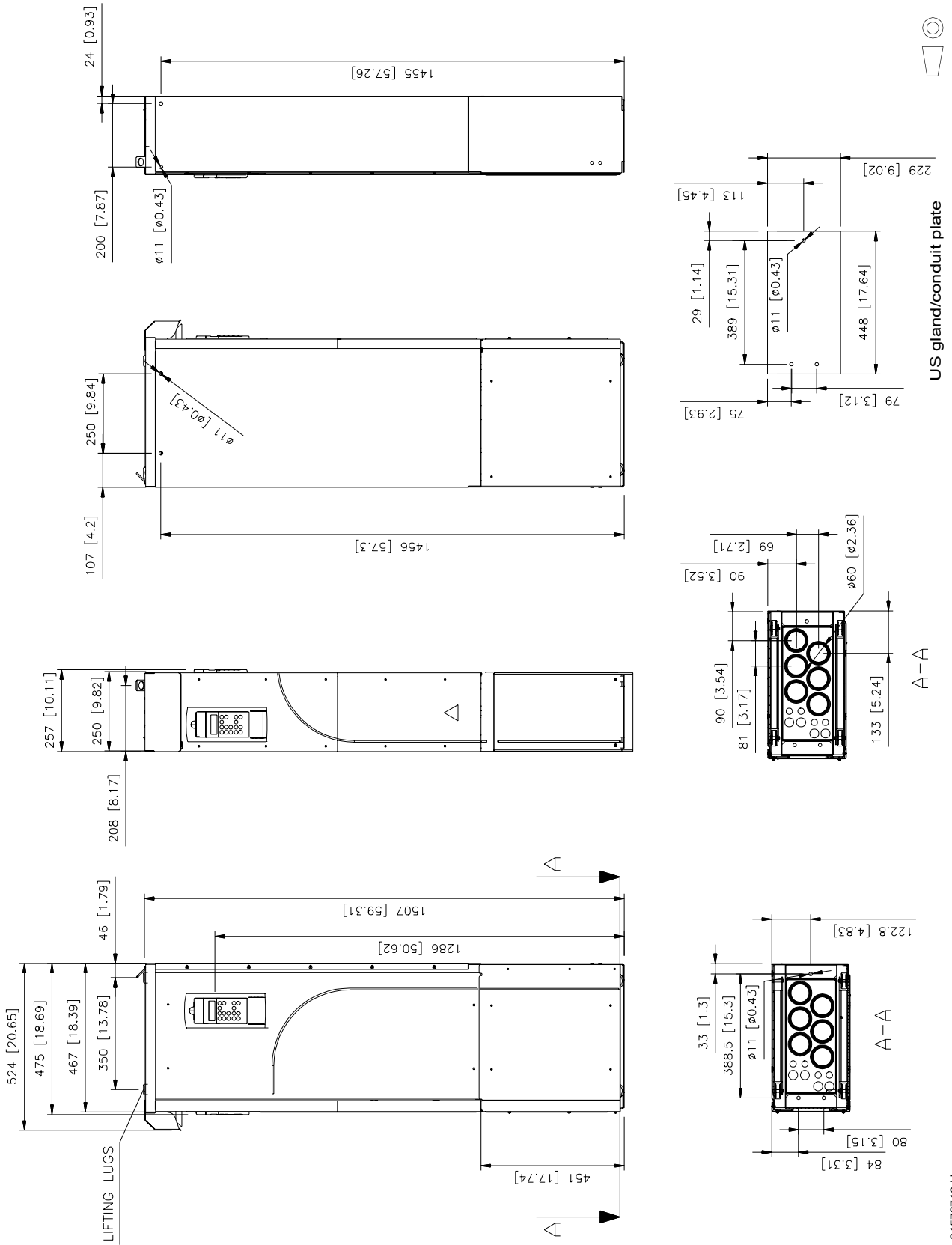

Frame size R8

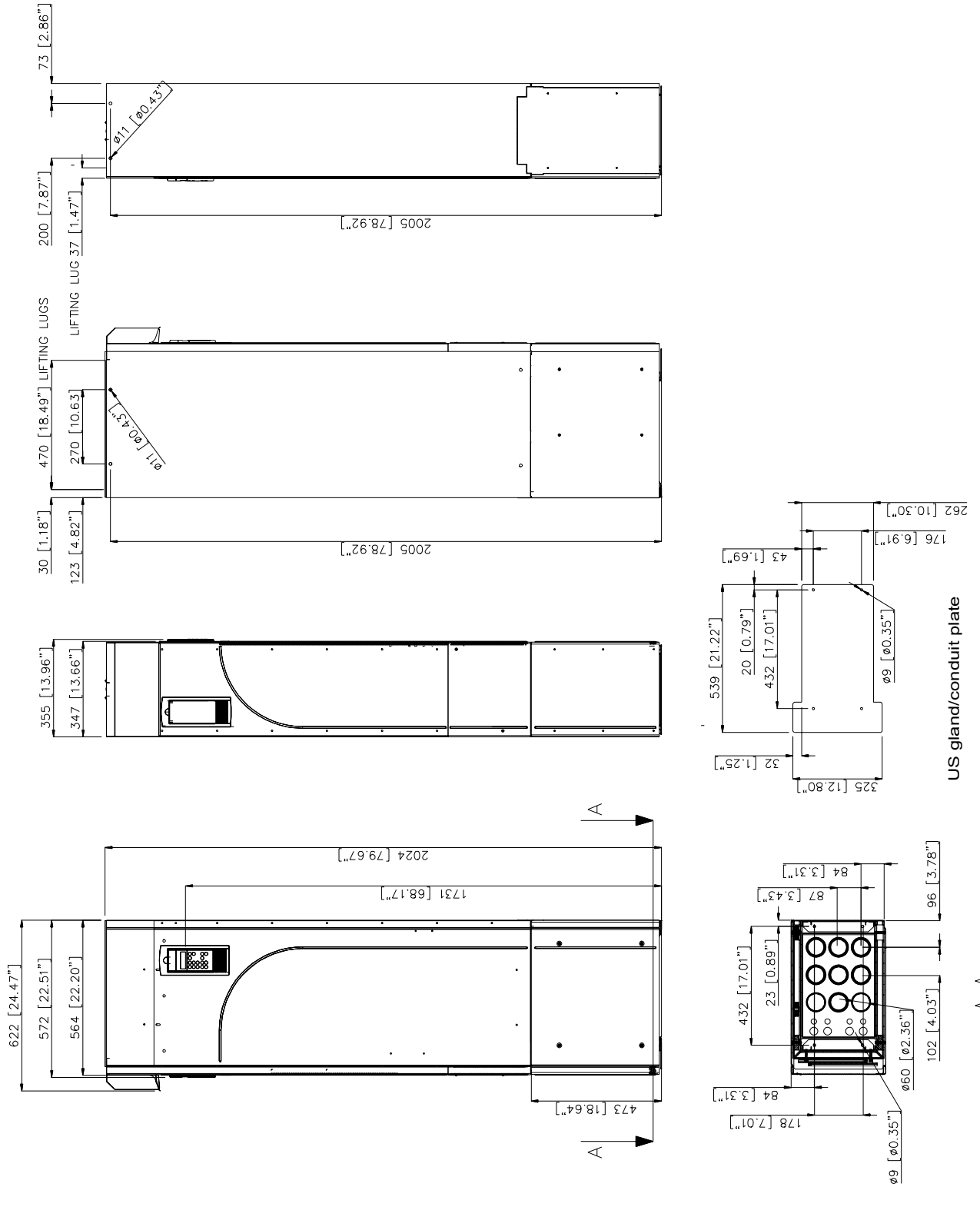

SAFE 64564161-D

A-A

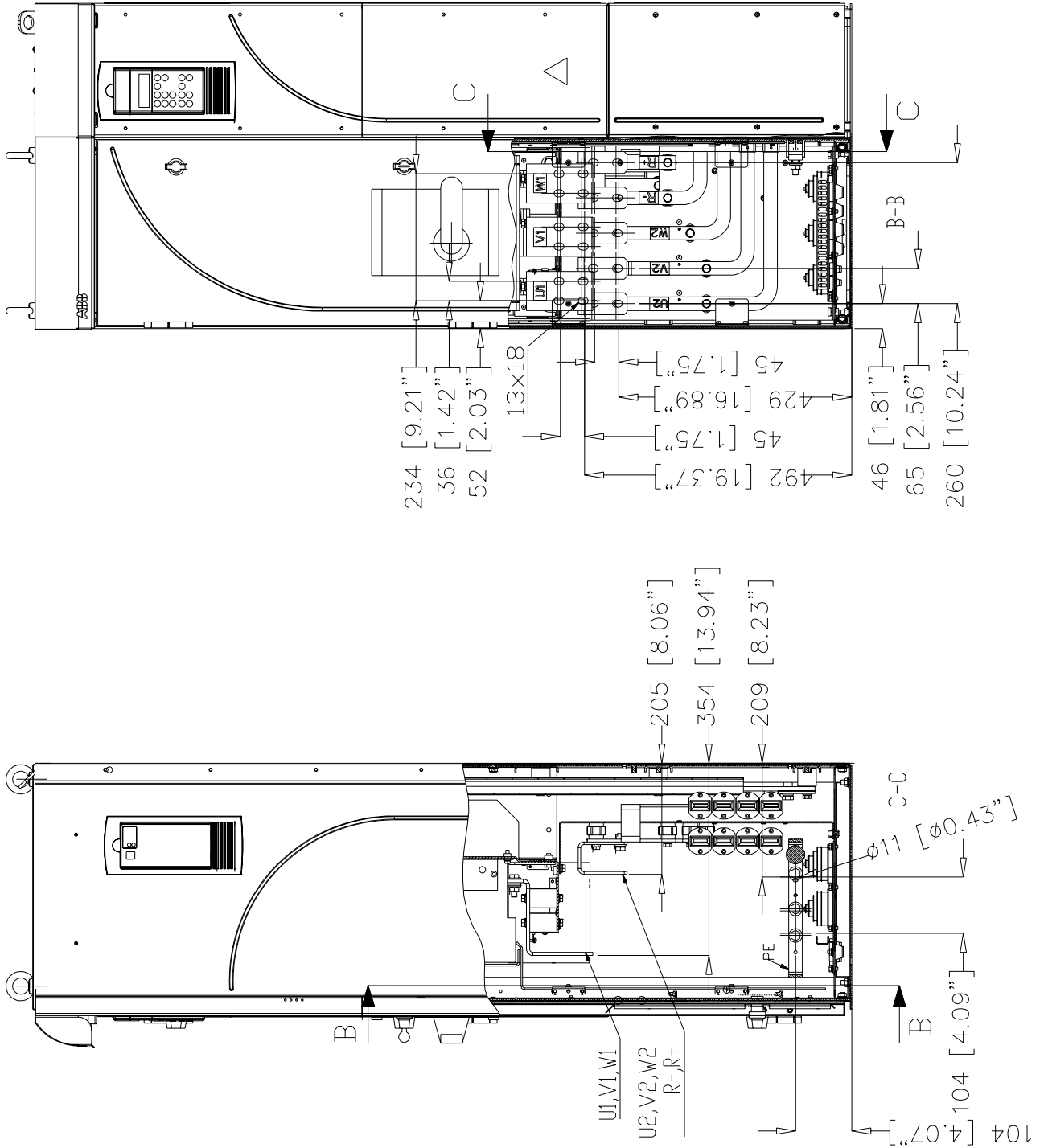

64625942 2/2 - C

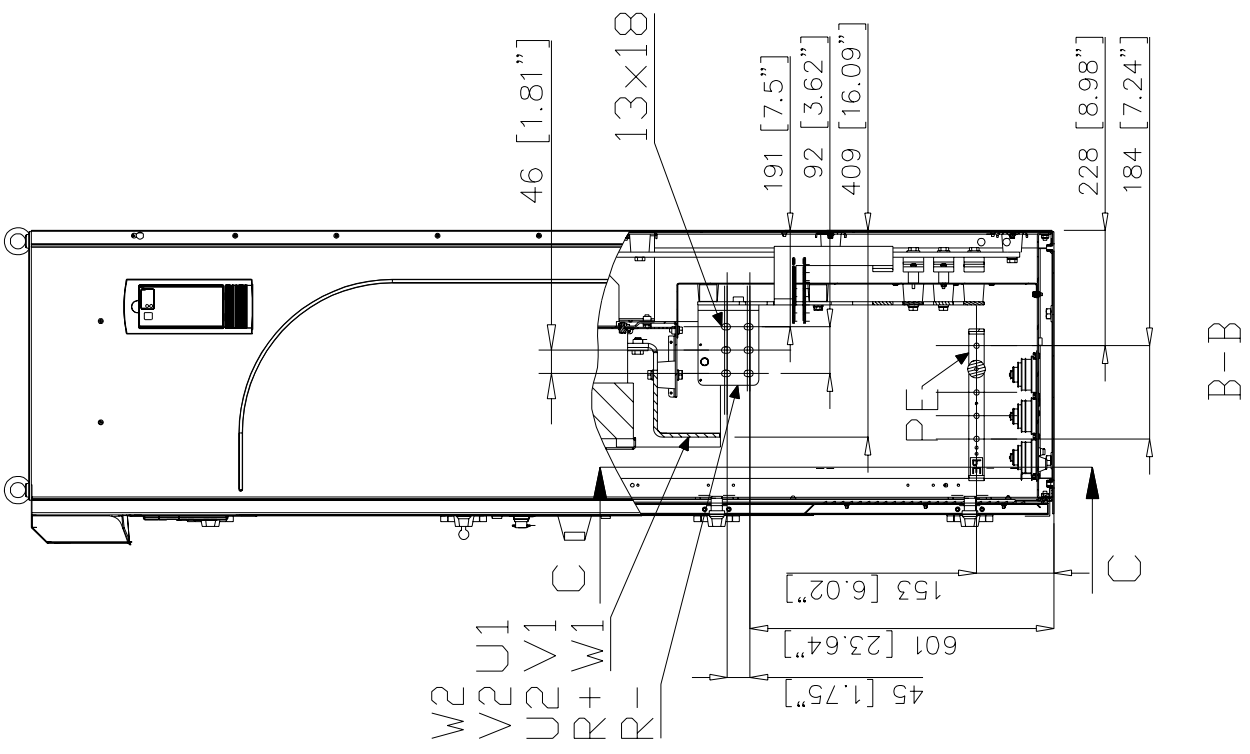
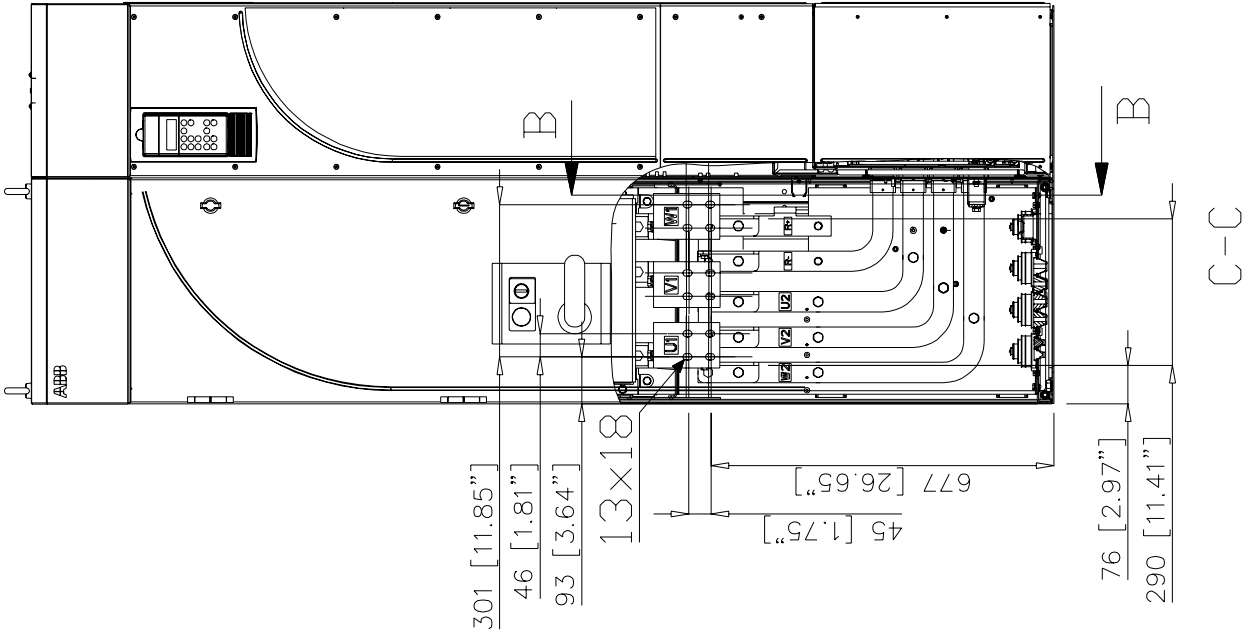

3AFE 64626388 2/2 - B

Frame size R8 with enclosure extension – top entry

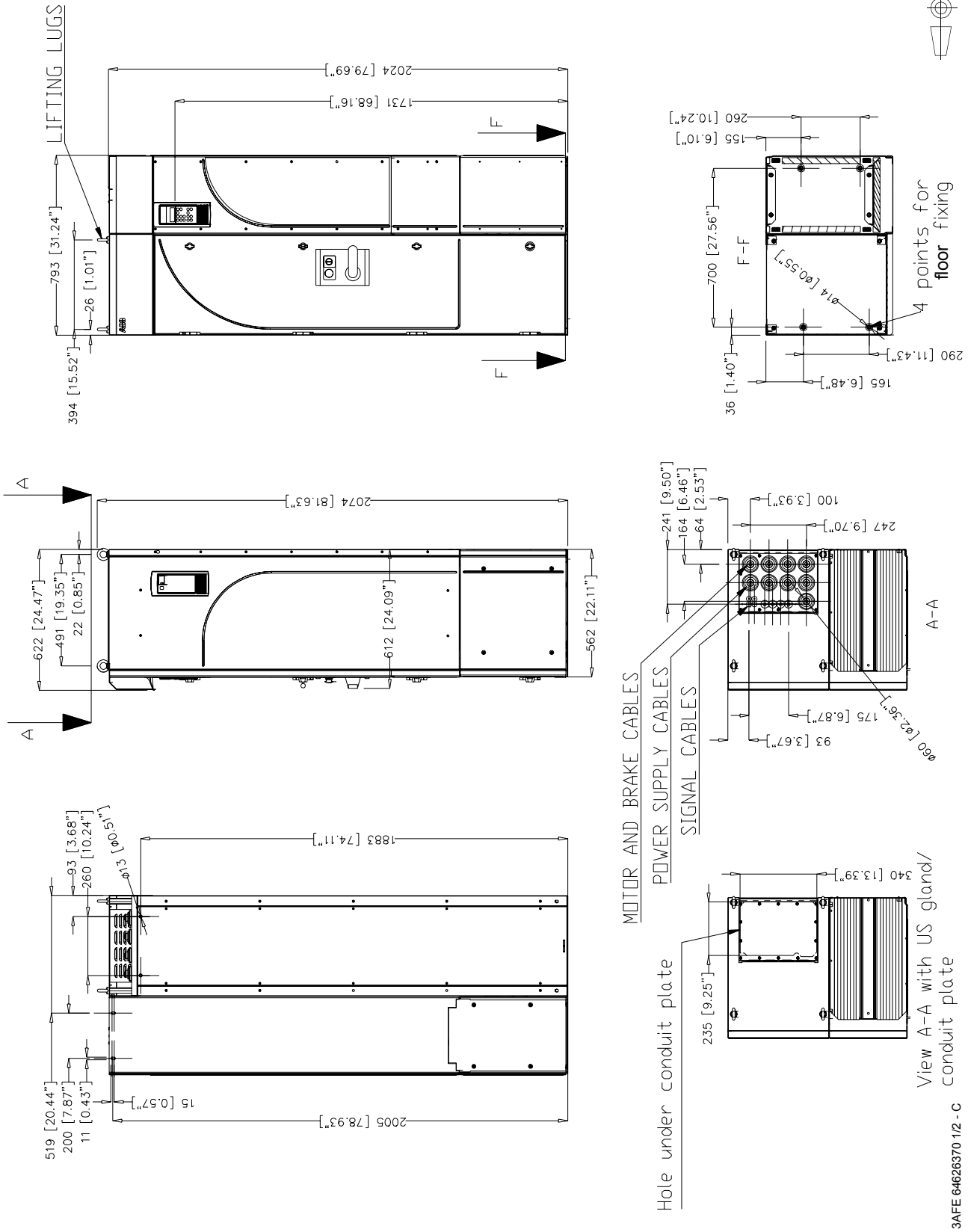

3AFE 64626370 1/2 - C

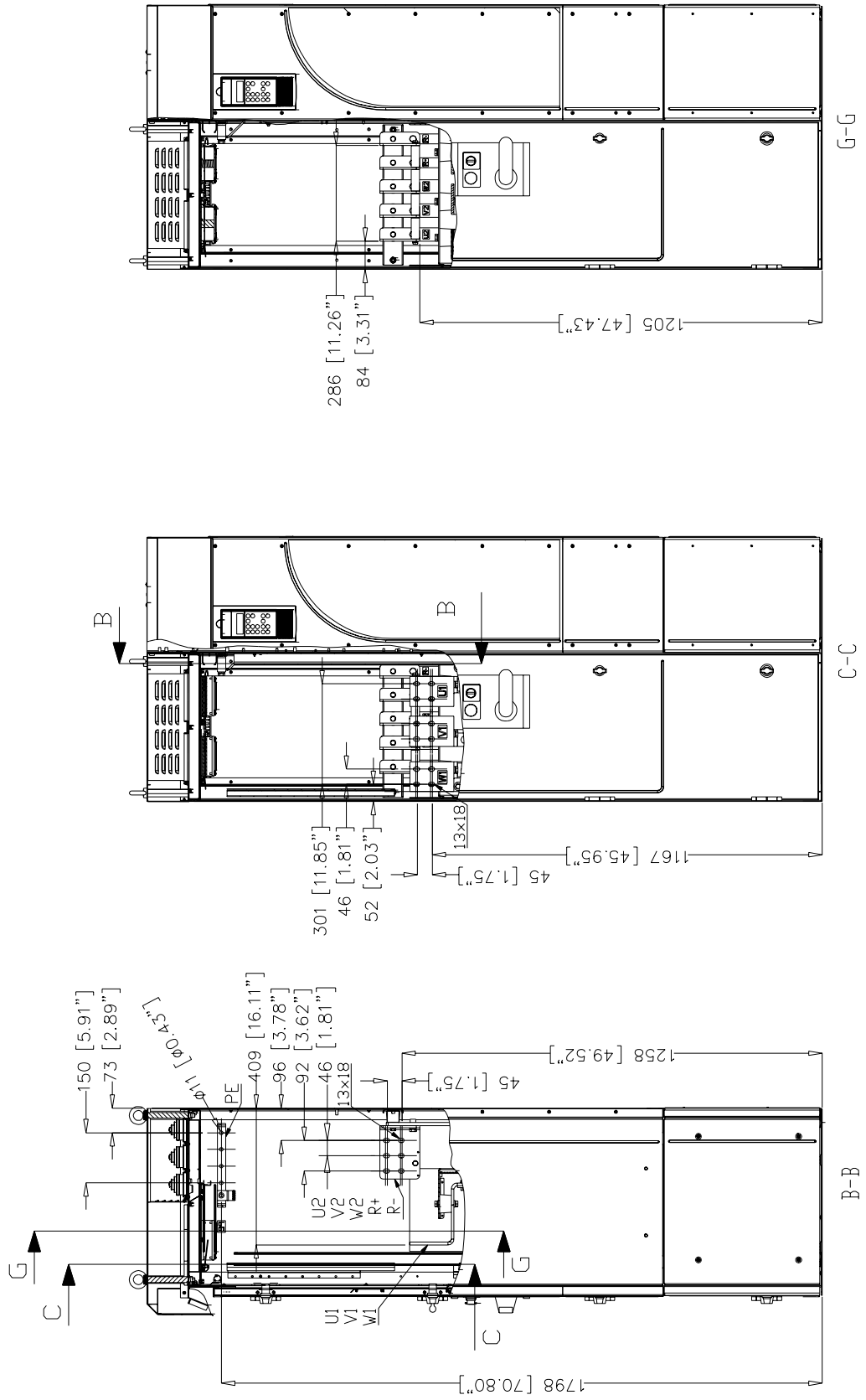

3AFE 64626370 2/2 -C

Resistor braking

What this chapter contains

This chapter describes how to select, protect and wire brake choppers and resistors. The chapter also contains the technical data.

To which products this chapter applies

This chapter applies to the ACS800-01/U1 (frame sizes R2 to R6), ACS800-02/U2 (frame sizes R7 and R8), ACS800-04/U4 (frame sizes R7 and R8) and ACS800-07/U7 (frame sizes R6, R7 and R8).

Availability of brake choppers and resistors for the ACS800

Frame R2 and R3 drives and 690 V units of frame size R4 have a built-in brake chopper as standard equipment. For other units, brake choppers are optionally available as built-in units, indicated in the type code by +D150.

Resistors are available as add-on kits. For the ACS800-07/U7, resistors are available as factory installed.

How to select the correct drive/chopper/resistor combination

1. Calculate the maximum power (P_{\max}) generated by the motor during braking.
2. Select a suitable drive / brake chopper / brake resistor combination for the application according to the following tables (take account of other factors in the drive selection also). The following condition must be met:

$$P_{\text{brcont}} \geq P_{\max}$$

where

P_{br} denotes P_{br5} , P_{br10} , P_{br30} , P_{br60} , or P_{brcont} depending on the duty cycle.

3. Check the resistor selection. The energy generated by the motor during a 400-second period must not exceed the resistor heat dissipation capacity E_R .

If the E_R value is not sufficient, it is possible to use a four-resistor assembly in which two standard resistors are connected in parallel, two in series. The E_R value of the four-resistor assembly is four times the value specified for the standard resistor.

Note: A resistor other than the standard resistor can be used provided that:

- its resistance is not lower than the resistance of the standard resistor.



WARNING! Never use a brake resistor with a resistance below the value specified for the particular drive / brake chopper / resistor combination. The drive and the chopper are not able to handle the overcurrent caused by the low resistance.

- the resistance does not restrict the braking capacity needed, i.e.,

$$P_{\max} < \frac{U_{\text{DC}}^2}{R}$$

where

P_{\max} maximum power generated by the motor during braking

U_{DC} voltage over the resistor during braking, e.g.,

1.35 · 1.2 · 415 VDC (when supply voltage is 380 to 415 VAC),

1.35 · 1.2 · 500 VDC. (when supply voltage is 440 to 500 VAC) or

1.35 · 1.2 · 690 VDC (when supply voltage is 525 to 690 VAC).

R resistor resistance (ohm)

- the heat dissipation capacity (E_R) is sufficient for the application (see step 3 above).

Optional brake chopper and resistor(s) for the ACS800-01/U1

The nominal ratings for dimensioning the brake resistors for the ACS800-01 and ACS800-U1 are given below at an ambient temperature of 40 °C (104 °F).

ACS800-01 type ACS800-U1 type	Braking power of the chopper and the drive P_{brcont} (kW)	Brake resistor(s)			
		Type	R (ohm)	E_R (kJ)	P_{Rcont} (kW)
230 V units					
-0001-2	0.55	SACE08RE44	44	210	1
-0002-2	0.8	SACE08RE44	44	210	1
-0003-2	1.1	SACE08RE44	44	210	1
-0004-2	1.5	SACE08RE44	44	210	1
-0005-2	2.2	SACE15RE22	22	420	2
-0006-2	3.0	SACE15RE22	22	420	2
-0009-2	4.0	SACE15RE22	22	420	2
-0011-2	5.5	SACE15RE13	13	435	2
-0016-2	11	SAFUR90F575	8	1800	4.5
-0020-2	17	SAFUR90F575	8	1800	4.5
-0025-2	23	SAFUR80F500	6	2400	6
-0030-2	28	SAFUR125F500	4	3600	9
-0040-2	33	SAFUR125F500	4	3600	9
-0050-2	45	2xSAFUR125F500	2	7200	18
-0060-2	56	2xSAFUR125F500	2	7200	18
-0070-2	68	2xSAFUR125F500	2	7200	18

ACS800-01 type ACS800-U1 type	Braking power of the chopper and the drive	Brake resistor(s)			
		P_{brcont} (kW)	Type	R (ohm)	E_R (kJ)
400 V units					
-0003-3	1.1	SACE08RE44	44	210	1
-0004-3	1.5	SACE08RE44	44	210	1
-0005-3	2.2	SACE08RE44	44	210	1
-0006-3	3.0	SACE08RE44	44	210	1
-0009-3	4.0	SACE08RE44	44	210	1
-0011-3	5.5	SACE15RE22	22	420	2
-0016-3	7.5	SACE15RE22	22	420	2
-0020-3	11	SACE15RE22	22	420	2
-0025-3	23	SACE15RE13	13	435	2
-0030-3	28	SACE15RE13	13	435	2
-0040-3	33	SAFUR90F575	8	1800	4.5
-0050-3	45	SAFUR90F575	8	1800	4.5
-0060-3	56	SAFUR90F575	8	1800	4.5
-0075-3	70	SAFUR80F500	3	2400	6
-0070-3	68	SAFUR80F500	6	2400	6
-0100-3	83	SAFUR125F500	4	3600	9
-0120-3	113	SAFUR125F500	4	3600	9
-0135-3	132	SAFUR200F500	2.7	5400	13.5
-0165-3	132	SAFUR200F500	2.7	5400	13.5
500 V units					
-0004-5	1.5	SACE08RE44	44	210	1
-0005-5	2.2	SACE08RE44	44	210	1
-0006-5	3.0	SACE08RE44	44	210	1
-0009-5	4.0	SACE08RE44	44	210	1
-0011-5	5.5	SACE08RE44	44	210	1
-0016-5	7.5	SACE15RE22	22	420	2
-0020-5	11	SACE15RE22	22	420	2
-0025-5	15	SACE15RE22	22	420	2
-0030-5	28	SACE15RE13	13	435	2
-0040-5	33	SACE15RE13	13	435	2
-0050-5	45	SAFUR90F575	8	1800	4.5
-0060-5	56	SAFUR90F575	8	1800	4.5
-0070-5	68	SAFUR90F575	8	1800	4.5
-0105-5	83	SAFUR80F500	6	2400	6
-0100-5	83	SAFUR125F500	4	3600	9
-0120-5	113	SAFUR125F500	4	3600	9
-0140-5	135	SAFUR125F500	4	3600	9
-0165-5	160	SAFUR125F500	4	3600	9
-0205-5	160	SAFUR125F500	4	3600	9

ACS800-01 type ACS800-U1 type	Braking power of the chopper and the drive	Brake resistor(s)			
		P_{brcont} (kW)	Type	R (ohm)	E_R (kJ)
690 V units					
-0011-7	8	SACE08RE44	44	210	1
-0016-7	11	SACE08RE44	44	210	1
-0020-7	16	SACE08RE44	44	210	1
-0025-7	22	SACE08RE44	44	210	1
-0030-7	28	SACE15RE22	22	420	2
-0040-7	22/33 ¹⁾	SACE15RE22	22	420	2
-0050-7	45	SACE15RE13	13	435	2
-0060-7	56	SACE15RE13	13	435	2
-0070-7	68	SAFUR90F575	8	1800	4.5
-0100-7	83	SAFUR90F575	8	1800	4.5
-0120-7	113	SAFUR80F500	6	2400	6
-0145-7	160	SAFUR80F500	6	2400	6
-0175-7	160	SAFUR80F500	6	2400	6
-0205-7	160	SAFUR80F500	6	2400	6

PDM code 00096931-J

P_{brcont} The drive and the chopper will withstand this continuous braking power. The braking is considered continuous if the braking time exceeds 30 s.

Note: Check that the braking energy transmitted to the specified resistor(s) in 400 seconds does not exceed E_R .

R Resistance value for the listed resistor assembly. **Note:** This is also the minimum allowed resistance for the brake resistor.

E_R Short energy pulse that the resistor assembly withstands every 400 seconds. This energy will heat the resistor element from 40 °C (104 °F) to the maximum allowable temperature.

P_{Rcont} Continuous power (heat) dissipation of the resistor when placed correctly. Energy E_R dissipates in 400 seconds.

¹⁾ 22 kW with standard 22 ohm resistor and 33 kW with 32...37 ohm resistor

All braking resistors must be installed outside the converter module. The SACE brake resistors are built in an IP 21 metal housing. The SAFUR brake resistors are built in an IP 00 metal frame. **Note:** The SACE and SAFUR resistors are not UL listed

Optional brake chopper and resistor(s) for the ACS800-02/U2, ACS800-04/04M/U4 and ACS800-07/U7

The nominal ratings for dimensioning the brake resistors for the ACS800-02/U2, ACS800-04/04M/U4 and ACS800-07/U7 are given below at an ambient temperature of 40 °C (104 °F).

ACS800 type	Frame size	Braking power of the chopper and the drive				Brake resistor(s)			
		5/60 s	10/60 s	30/60 s	P_{brcont} (kW)	Type	R (ohm)	E_R (kJ)	P_{Rcont} (kW)
		P_{br5} (kW)	P_{br10} (kW)	P_{br30} (kW)					
230 V units									
-0080-2	R7	68	68	68	54	SAFUR160F380	1.78	3600	9
-0100-2	R7	83	83	83	54	SAFUR160F380	1.78	3600	9
-0120-2	R7	105	67	60	40	2xSAFUR200F500	1.35	10800	27
-0140-2	R8	135	135	135	84	2xSAFUR160F380	0.89	7200	18
-0170-2	R8	135	135	135	84	2xSAFUR160F380	0.89	7200	18
-0210-2	R8	165	165	165	98	2xSAFUR160F380	0.89	7200	18
-0230-2	R8	165	165	165	113	2xSAFUR160F380	0.89	7200	18
-0260-2	R8	223	170	125	64	4xSAFUR160F380	0.45	14400	36
-0300-2	R8	223	170	125	64	4xSAFUR160F380	0.45	14400	36
400 V units									
-0070-3	R6	-	-	-	68	SAFUR80F500	6	2400	6
-0100-3	R6	-	-	-	83	SAFUR125F500	4	3600	9
-0120-3	R6	-	-	-	113	SAFUR125F500	4	3600	9
-0130-3*	R6	-	-	-	113	SAFUR125F500	4	3600	9
-0140-3	R7	135	135	100	80	SAFUR200F500	2.70	5400	13.5
-0170-3	R7	165	150	100	80	SAFUR200F500	2.70	5400	13.5
-0210-3	R7	165	150	100	80	SAFUR200F500	2.70	5400	13.5
-0260-3	R8	240	240	240	173	2XSAFUR210F575	1.70	8400	21
-0320-3	R8	300	300	300	143	2xSAFUR200F500	1.35	10800	27
-0400-3	R8	375	375	273	130	4xSAFUR125F500	1.00	14400	36
-0440-3	R8	473	355	237	120	4xSAFUR210F575	0.85	16800	42
-0490-3	R8	500	355	237	120	4xSAFUR210F575	0.85	16800	42
500 V units									
-0100-5	R6	-	-	-	83	SAFUR125F500	4	3600	9
-0120-5	R6	-	-	-	113	SAFUR125F500	4	3600	9
-0140-5	R6	-	-	-	135	SAFUR125F500	4	3600	9
-0150-5*	R6	-	-	-	135	SAFUR125F500	4	3600	9
-0170-5	R7	165	132 ²⁾	120	80	SAFUR200F500	2.70	5400	13.5
-0210-5	R7	198	132 ²⁾	120	80	SAFUR200F500	2.70	5400	13.5
-0260-5	R7	198 ¹⁾	132 ²⁾	120	80	SAFUR200F500	2.70	5400	13.5
-0270-5**	R8	240	240	240	240	2xSAFUR125F500	2.00	7200	18
-0300-5**	R8	280	280	280	280	2xSAFUR125F500	2.00	7200	18
-0320-5	R8	300	300	300	300	2xSAFUR125F500	2.00	7200	18
-0400-5	R8	375	375	375	234	2XSAFUR210F575	1.70	8400	21
-0440-5	R8	473	473	450	195	2xSAFUR200F500	1.35	10800	27
-0490-5	R8	480	480	470	210	2xSAFUR200F500	1.35	10800	27
-0550-5	R8	600	400 ⁴⁾	300	170	4xSAFUR125F500	1.00	14400	36
-0610-5	R8	600 ³⁾	400 ⁴⁾	300	170	4xSAFUR125F500	1.00	14400	36

ACS800 type	Frame size	Braking power of the chopper and the drive				Brake resistor(s)			
		5/60 s	10/60 s	30/60 s		Type	R (ohm)	E _R (kJ)	P _{Rcont} (kW)
		P _{br5} (kW)	P _{br10} (kW)	P _{br30} (kW)	P _{brcont} (kW)				
690 V units									
-0070-7	R6	-	-	-	45	SAFUR90F575	8.00	1800	4.5
-0100-7	R6	-	-	-	55	SAFUR80F500	6.00	2400	6
-0120-7	R6	-	-	-	75	SAFUR80F500	6.00	2400	6
-0140-7	R7	125 ⁵⁾	110	90	75	SAFUR80F500	6.00	2400	6
-0170-7	R7	125 ⁶⁾	110	90	75	SAFUR80F500	6.00	2400	6
-0210-7	R7	125 ⁶⁾	110	90	75	SAFUR80F500	6.00	2400	6
-0260-7	R7	135 ⁷⁾	120	100	80	SAFUR200F500	6.00	2400	6
-0320-7	R8	300	300	300	260	SAFUR200F500	2.70	5400	13.5
-0400-7	R8	375	375	375	375	SAFUR200F500	2.70	5400	13.5
-0440-7	R8	430	430	430	385	SAFUR200F500	2.70	5400	13.5
-0490-7	R8	550	400	315	225	2xSAFUR125F500	2.00	7200	18
-0550-7	R8	550	400	315	225	2xSAFUR125F500	2.00	7200	18
-0610-7	R8	550	400	315	225	2xSAFUR125F500	2.00	7200	18

PDM code 00096931-J

P_{br5} Maximum braking power of the drive with the specified resistor(s). The drive and the chopper will withstand this braking power for 5 seconds per minute.

P_{br10} The drive and the chopper will withstand this braking power for 10 seconds per minute.

P_{br30} The drive and the chopper will withstand this braking power for 30 seconds per minute.

P_{brcont} The drive and the chopper will withstand this continuous braking power. The braking is considered continuous if the braking time exceeds 30 s.

Note: Check that the braking energy transmitted to the specified resistor(s) in 400 seconds does not exceed E_R.

R Resistance value for the resistor assembly. **Note:** This is also the minimum allowed resistance for the brake resistor.

E_R Short energy pulse that the resistor assembly withstands every 400 seconds. This energy will heat the resistor element from 40 °C (104 °F) to the maximum allowable temperature.

P_{Rcont} Continuous power (heat) dissipation of the resistor when placed correctly. Energy E_R dissipates in 400 seconds.

* ACS800-0x types only

** ACS800-Ux types only

1) 240 kW possible if ambient temperature is below 33 °C (91 °F)

2) 160 kW possible if ambient temperature is below 33 °C (91 °F)

3) 630 kW possible if ambient temperature is below 33 °C (91 °F)

4) 450 kW possible if ambient temperature is below 33 °C (91 °F)

5) 135 kW possible if ambient temperature is below 33 °C (91 °F)

6) 148 kW possible if ambient temperature is below 33 °C (91 °F)

7) 160 kW possible if ambient temperature is below 33 °C (91 °F)

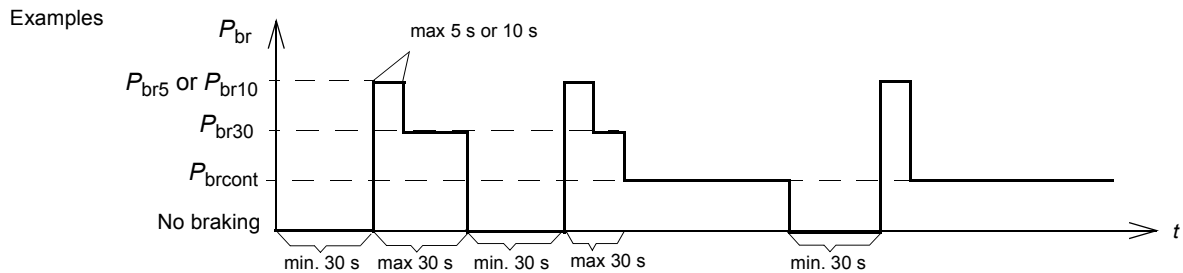
Combined braking cycles for R7:

- After P_{br5} , P_{br10} or P_{br30} braking, the drive and the chopper will withstand P_{brcont} continuously.
- P_{br5} , P_{br10} or P_{br30} braking is allowed once every minute.
- After P_{brcont} braking, there has to be a pause of at least 30 seconds without any braking if the subsequent braking power is greater than P_{brcont} .
- After P_{br5} or P_{br10} braking, the drive and the chopper will withstand P_{br30} within a total braking time of 30 seconds.
- P_{br10} braking is not acceptable after P_{br5} braking.

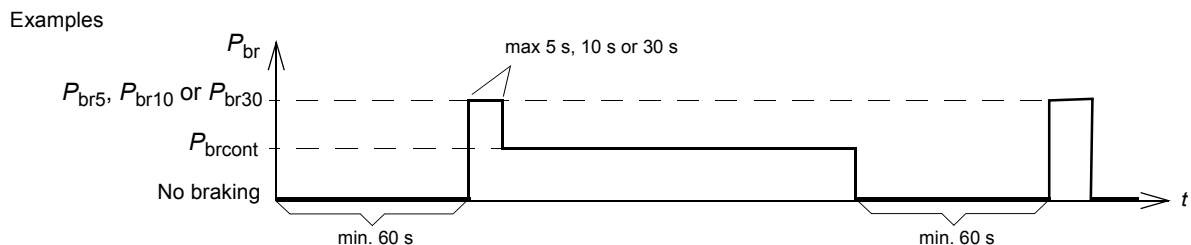
Combined braking cycles for R8:

- After P_{br5} , P_{br10} or P_{br30} braking, the drive and the chopper will withstand P_{brcont} continuously. (P_{brcont} is the only allowed braking power after P_{br5} , P_{br10} or P_{br30} .)
- P_{br5} , P_{br10} or P_{br30} braking is allowed once every minute.
- After P_{brcont} braking, there has to be a pause of at least 60 seconds without any braking if the subsequent braking power is greater than P_{brcont} .

All braking resistors must be installed outside the converter module. The resistors are built in an IP 00 metal frame. The 2xSAFUR and 4xSAFUR resistors are connected in parallel. **Note:** The SAFUR resistors are not UL listed.

Resistor installation and wiring

All resistors must be installed outside the drive module in a place where they will cool.



WARNING! The materials near the brake resistor must be non-flammable. The surface temperature of the resistor is high. Air flowing from the resistor is of hundreds of degrees Celsius. Protect the resistor against contact.

Use the cable type used for drive input cabling (refer to chapter *Technical data*) to ensure the input fuses will also protect the resistor cable. Alternatively, two-conductor shielded cable with the same cross-sectional area can be used. The maximum length of the resistor cable(s) is 10 m (33 ft). For the connections, see the power connection diagram of the drive.

ACS800-07/U7

If ordered, the resistors are factory installed in a cubicle(s) next to the drive cabinet.

Protection of frame sizes R2 to R5 (ACS800-01/U1)

It is highly recommended to equip the drive with a main contactor for safety reasons. Wire the contactor so that it opens in case the resistor overheats. This is essential for safety since the drive will not otherwise be able to interrupt the main supply if the chopper remains conductive in a fault situation.

Below is a simple example wiring diagram.

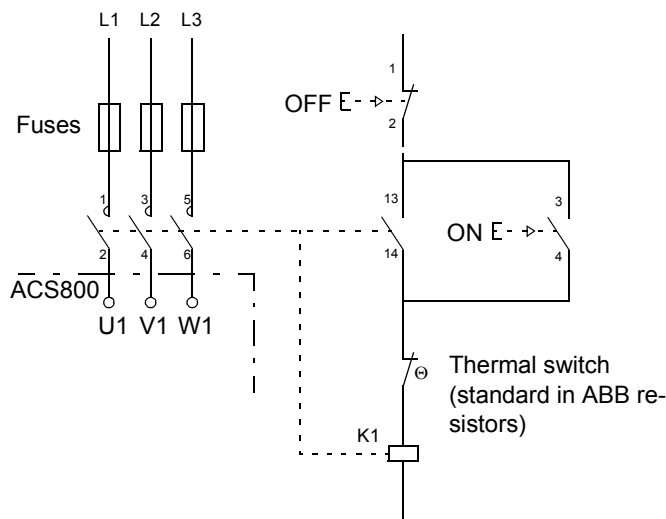

Protection of frame size R6 (ACS800-01, ACS800-07) and frame sizes R7 and R8 (ACS800-02, ACS800-04, ACS800-07)

A main contactor is not required for protecting against resistor overheating when the resistor is dimensioned according to the instructions and the internal brake chopper is in use. The drive will disable power flow through the input bridge if the chopper remains conductive in a fault situation. **Note:** If an external brake chopper (outside the drive module) is used, a main contactor is always required.

A thermal switch (standard in ABB resistors) is required for safety reasons. The cable must be shielded and not longer than the resistor cable.

With Standard Control Program, wire the thermal switch as shown below. By default, the drive will stop by coasting when the switch opens.

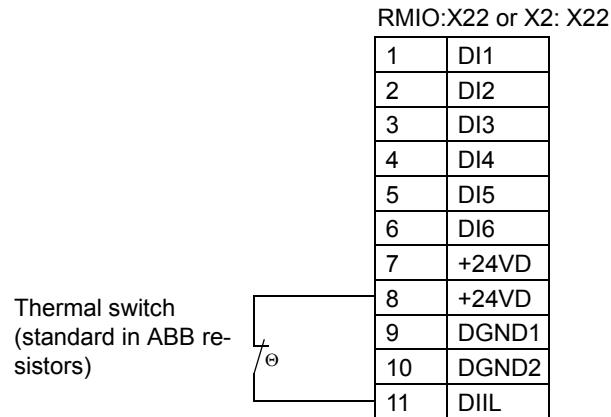

For other control programs, the thermal switch may be wired to a different digital input. Programming of the input to trip the drive by “EXTERNAL FAULT” may be needed. See the appropriate firmware manual.

Brake circuit commissioning

For Standard Control Program:

- Enable the brake chopper function (parameter 27.01).
- Switch off the overvoltage control of the drive (parameter 20.05).
- Check the resistance value setting (parameter 27.03).
- Frame sizes R6, R7 and R8: Check the setting of parameter 21.09. If stop by coasting is required, select OFF2 STOP.

For the use of the brake resistor overload protection (parameters 27.02...27.05), consult an ABB representative.



WARNING! If the drive is equipped with a brake chopper but the chopper is not enabled by parameter setting, the brake resistor must be disconnected because the protection against resistor overheating is then not in use.

For settings of other control programs, see the appropriate firmware manual.

Non-ABB du/dt filter selection

What this chapter contains

This chapter contains guidelines for selecting and installing a non-ABB du/dt filter with the drive.

When a du/dt filter must be used

A du/dt filter must be used with drives of voltages from 500 V to 690 V according to the *Requirements table* on page 32.

Filter and installation requirements

1. The filter is an LCR filter or an L filter (i.e. a series inductor: three single-phase inductors or one three-phase inductor).

Check that the approximate per-phase impedance of the filter inductor is 1.5 % for drives of frame size R7 and 2 % for drives of frame size R8 when calculated as follows:

$$Z_L = 2 \cdot \pi \cdot f_N \cdot L \cdot \frac{\sqrt{3} \cdot I_N}{U_N} \cdot 100$$

where

- Z_L $\hat{=}$ impedance of the inductor divided by the nominal phase impedance of the motor, in percentage
- L $\hat{=}$ per-phase inductance of the filter
- f_N $\hat{=}$ rated motor frequency
- I_N $\hat{=}$ rated motor current
- U_N $\hat{=}$ rated motor voltage.

Note: Impedances over 1.5 % or 2 % can be used, but then the voltage drop across the filter will be increased, thus reducing the pull-out torque and attainable power.

2. The du/dt value of the inverter output voltage is approximately 5 kV / microsecond. The filter limits the du/dt value at the motor terminals to less than 1 kV / microsecond.
3. The filter withstands the continuous current of the drive ($I_{\text{cont.max}}$). Saturation of the filter core is not allowed up to the maximum output current of the drive (I_{max}).
4. The filter is dimensioned thermally to withstand a switching frequency of 2 kHz with 690 V units, and 3 kHz with 500 V units.
5. The cable between the drive and the filter is shorter than the maximum length specified by the filter manufacturer.

6. The motor cable does not exceed the maximum length specified by the filter manufacturer and *ACS800-02/U2 Hardware Manual*.
7. Maximum output frequency does not exceed the limit specified by the filter manufacturer and 300 Hz specified by the drive.



3AFE64567373 Rev F EN
EFFECTIVE: 15.8.2007

ABB Oy

AC Drives
P.O. Box 184
FI-00381 HELSINKI
FINLAND

Telephone +358 10 22 11
Fax +358 10 22 22681
Internet www.abb.com

ABB Inc.

Automation Technologies
Drives & Motors
16250 West Glendale Drive
New Berlin, WI 53151
USA

Telephone 262 785-3200
800-HELP-365
Fax 262 780-5135

ABB Beijing Drive Systems Co. Ltd.

No. 1, Block D, A-10 Jiuxianqiao Beilu
Chaoyang District
Beijing, P.R. China, 100015

Telephone +86 10 5821 7788
Fax +86 10 5821 7618
Internet www.abb.com